



Gastro-Haal

USER MANUAL

for installation and maintenance

TILTING BRATT PANS

electric with filling of water and
cast iron bottom of the cooking tank

Practic 



PRODUCT LINE:

PRACTIC

P.PE-750 C, P.PE-980 C, P.PE-9120 C

Issued: 2/2025

CE ₁₂₉₉

Content

1. General information	3
2. Use	3
3. Safety regulations	3
4. Legal regulations	3
5. Technical data	5
6. Description	6
7. Installation	6
8. Operation	6
9. Turning the equipment on	7
9.1. Switching the equipment on	7
9.2. Filling of water to cooking tank	8
9.3. Temperature setting (regulation)	8
9.4. Turning the equipment off.....	9
9.5. Emptying the cooking tank	9
10. Safety features	10
11. Safety instructions	11
12. Maintenance and cleaning of the equipment	11
13. Connection dimensions	12
14. Electrical wiring diagram	15

The contact details of the supplier and service provider can be found on page 18.



<https://gastrohaal.sk/en/product-registration>

1. General information

Dear user, thank you for choosing our product. Please read these operating instructions carefully before using the equipment so that the equipment can serve you to your satisfaction.

2. Use

The Gastro-Haal electric equipment from the Practic product line is designed for preparing various types of dishes and meals. Food is prepared by heat treatment - frying in oil, stewing in water. The equipment are used in large kitchens, catering establishments, buffets, bistros and fast food stands.

3. Safety regulations

The manufacturer declares that the equipment are in compliance with the regulations and applicable decrees of the European Union and the relevant government regulations.

Attention! The manufacturer disclaims any liability in the event of direct and indirect damages related to improper installation, improper assembly or other causes.

The equipment must only be operated by qualified persons. Parts set by the manufacturer, or a specialist service are strictly forbidden for the user to rebuild. It is forbidden to touch any parts of the equipment other than those specified by the control and manufacturer during operation. Furthermore, it is forbidden to clean and wash the equipment during operation. It is forbidden to use the equipment for any purpose other than that specified in the manual. Maintenance and repair can only be carried out when the equipment is switched off from the mains.

Inspection by service personnel designated by the manufacturer once a year is recommended. When replacing spare parts, original spare parts must be used.

The manufacturer is not responsible for defects caused by improper installation and operation.

4. Legal regulations

CUSTOMER WHO HAS BEEN ASSEMBLED, ADJUSTED AND REPAIRED BY AN ORGANISATION NOT AUTHORISED BY THE MANUFACTURING ORGANISATION CANNOT CLAIM THE COSTS ASSOCIATED WITH THE WARRANTY REPAIR WITH THE MANUFACTURER.

The operator using the equipment must read the Installation and Maintenance Instructions in detail. Furthermore, the person responsible for the buyer is obliged to participate, together with the operating staff, in professional training in accordance with the document Operation and Maintenance Protocol, which is an annex to the Installation and Maintenance Instructions and is required to be confirmed by the signature of the responsible person and the buyer's stamp. Professional training according to the above takes place during the installation / assembly of the equipment by an authorized service technician. In the event of improper use and operation of the equipment, the right to warranty repair is lost!!!

The manufacturer will provide a warranty for the equipment according to the enclosed " Warranty certificate".

Defects that can be rectified by the user are not considered to be defects subject to warranty.
Defects covered by the warranty will be repaired by the manufacturer's service organization or its representative.

Warning!

THE MANUFACTURER IS NOT RESPONSIBLE FOR THE INCORRECT TECHNOLOGICAL PROCEDURE OF THE OPERATOR DURING COOKING.

5. Technical data

Line	700	900	900
Type	P.PE-750 C	P.PE-980 C	P.PE-9120 C
Product line	Practic	Practic	Practic
Equipment	electric tilting bratt pan	electric tilting bratt pan	electric tilting bratt pan
Front panel	classic analogy	classic analogy	classic analogy
Material of bottom cooking tank	cast iron	cast iron	cast iron
External dimensions (mm) w x d x h	800x700x900 mm	900x900x900 mm	1200x900x900 mm
Dimensions of the cooking tank (mm) w x d x h	700x435x158 mm	800x600x190 mm	1100x600x210 mm
Volume of the cooking tank (l)	50,1 l	94,6 l	147,3 l
Volume up to the spout on cooking tank (l)	42,6 l	82,3 l	130,2 l
Usable volume of the cooking tank (max. line) (l)	37,4 l	75,2 l	120 l
Weight (kg)	125 kg	160 kg	180 kg
Heating			
Heating elements (pcs)	6 pcs	9 pcs	12 pcs
Nominal el. input (kW)	9 kW	13,5 kW	18 kW
Nominal voltage (V)	3 N - 50 Hz / 400V TN-S	3 N - 50 Hz / 400V TN-S	3 N - 50 Hz / 400V TN-S
Nominal current (A)	13,5 A	21 A	27 A
Thermostat range (°C)	50 - 250 °C	50 - 250 °C	50 - 250 °C
Possible cooking temperature (°C)	50 - 250 °C	50 - 250 °C	50 - 250 °C
Water, protection			
Cold water connection (")	3/4"	3/4"	3/4"
Index of protection	IP 41	IP 41	IP 41
Index IP control elements	IP 65	IP 65	IP 65
Automatic water filling with tap using a button	yes	yes	yes
Construction, savings, safety			
Tap for cold water	yes	yes	yes
Double insulation on cables and wires (silicone protection)	yes	yes	yes
Rounded edges without danger corners and protrusions	yes	yes	yes
Adjustable feet	yes	yes	yes
Options for extra fees according of valid Price list			
Square steamer	yes (extra fee)	yes (extra fee)	yes (extra fee)
Strainer	yes (extra fee)	yes (extra fee)	yes (extra fee)

6. Description

The equipment is made of **food-safe stainless steel**. In the upper part of the equipment there is a working cooking tank with a lid, which is connected to the support frame and is placed on sliding bearings. The cooking tank can be tilted manually using a rotating wheel located in the right part of the equipment. The frame of the equipment is self-supporting and is mounted on four adjustable feet. The equipment is also equipped with a working thermostat, which is located under the front cover of the equipment in an electrical box mounted on the support frame. On the support frame of the equipment in the rear part there is a limit microswitch, which controls the disconnection of the electrical circuit when the cooking tank is tilted. Equipment are equipped with heating elements, which are attached with fastening screws to the lower part (bottom) of the cooking tank.

7. Installation

Only personnel of the servicing organisation may install the equipment. Service is also provided by the seller or an assembly organization authorized to install electrical equipment. Equipment can also be installed in a block unit. If the equipment is located near kitchen units or flammable substances, fire protection regulations must be observed. Fire protection must always be guaranteed!!! We recommend placing the equipment under a hood.

The Gastro-Haal equipment from the Practic product line is always installed on a fixed electrical line. The following instructions must be observed during assembly:

- **Attention!** Before removing the protective covers from the terminals, the power supply must be disconnected from the power supply.
- The equipment is placed in a previously prepared place with a secure electrical connection 3N~50 Hz/400 V.
- The equipment is adjusted to a horizontal position using the height-adjustable feet.
- Use an Allen key to remove the rotating wheel for tilting the cooking tank.
- Under the front cover of the pan there is a 400 V connection terminal block. This panel is dismantled using four screws, which are located - two in the upper part of the cover and two in the lower part.
- The mains voltage must match the voltage indicated on the label.
- A cable with a rubber sheath that is not resistant to oil must not be used.
- After connecting the mains supply, re-install the front cover in its original place.
- The equipment must be connected to the mains via a switch with a minimum contact distance of 3 mm and the switch must be located on the wall near the equipment!
- **The equipment must be grounded!!!** There is a protective terminal on the bottom of the equipment (ground) that serves to connect non-live metal parts of kitchen equipment. The meaning of this terminal is that the wire that we connect to it ensures that all metal equipment are brought to the same potential.
- The connection may only be carried out by a qualified specialist in accordance with the applicable standards and regulations of the electrical wiring diagram.

8. Operation

Improper handling is dangerous. The manufacturer is not liable for material damage if this occurs due to improper handling (when putting the equipment into operation or during operation). The operator is obliged

to thoroughly familiarize the operating personnel with these instructions, as well as those who only work with the equipment occasionally. The pan must be used under constant supervision. The equipment may only be used for the purposes for which it is intended. Any other use is forbidden, as it may cause danger. Keep the instructions carefully but ensure that they are accessible to the operator.

9. Turning the equipment on

Warning: Do not turn on the equipment if there is no water/oil in the cooking tank! This reduces the lifetime of the equipment (the cooking tank may overheat and warp)!

9.1. Switching the equipment on



The equipment is put into operation by turning on **the main switch**. The green light on the switch indicates that equipment is powered.

Control panel consists of:

	<p>1. Rotary knob Rotary knob for setting the cooking temperature in range from 50°C to 250°C.</p>
	<p>2. Main switch - control of electricity ON/OFF - green light signals that equipment is in operation</p>
	<p>3. Heating lights - switching on the working thermostat to operation</p>
	<p>4. Switch for filling of water from tap to cooking tank - after pressing and the lightning of button, the water is filled into cooking tank - after another pressing, the button stops lighting, and the water filling stops This is a manual operation that is controlled manually, not automatically.</p>

Picture: **Control panel of tilting bratt pan Practic:**

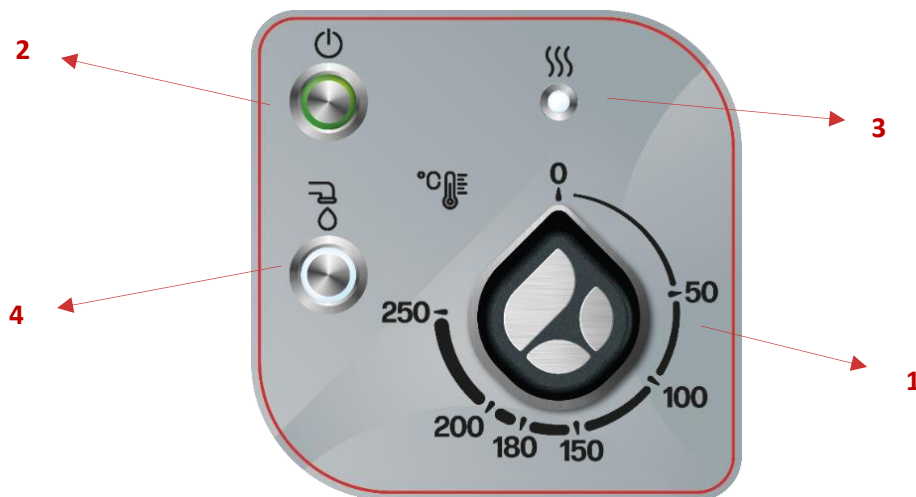

- 1 = Rotary knob for setting the heating temperature**
- 2 = Main switch**
- 3 = Heating light**
- 4 = Button for filling water into the cooking tank with the tap**

9.2. Filling of water to cooking tank



Open the lid on the equipment, turn on the water filling by switch  to fill the appropriate amount of water into the cooking tank. **Please monitor the water level, as the equipment does not monitor the level of the water entered! In the event of water overflowing from the cooking tank and subsequent damage to the equipment, the warranty for the equipment is NOT COVERED!**

9.3. Temperature setting (regulation)

Maintaining the temperature at the set value is automatic, this is ensured by the working thermostat. By turning the thermostat control knob clockwise to the desired value, we activate the equipment marked



values are given in °C. The heating indicator light will light up . After reaching the desired temperature in the cooking tank, the heating indicator light will turn off.

Warning: The working thermostat has a certain switching tolerance. Therefore, when heating up, we recommend setting a value 50 °C lower than the desired one and setting the desired temperature after heating up. The actual heating, cooking and baking time depends on the type and amount of food being cooked in the tank.

9.4. Turning the equipment off



Press the main switch to switch off, thereby disconnecting the equipment control circuit. This is also indicated by the main switch on the control panel going out. The equipment can be disconnected from the power supply via a switch with a minimum contact gap of 3 mm, which is located on the wall near the equipment.

9.5. Emptying the cooking tank

The cooking tank can only be emptied when the equipment is switched off.
The cooking tank is emptied using the manual rotary wheel located on the right side of the equipment.



By turning this wheel clockwise, the cooking tank begins to tilt, by turning it counterclockwise, the cooking tank returns to its original horizontal position. The direction is also indicated visually, with an icon.



The MAXIMUM and MINIMUM filling levels of the tank are marked with a line on the back wall of the cooking tank. **The manufacturer recommends that the bottom of the cooking tank be covered with a continuous layer of oil of at least 5 mm.** If the filling level does not reach the minimum level, uneven heat distribution may occur and thus permanent **deformation** of the bottom of the cooking tank may occur. Direct cooling of the heated bottom of the cooking tank (with cold water) is strictly forbidden for safety reasons and permanent deformation of the bottom of the cooking tank. Filling levels above the maximum level are also strictly forbidden for safety reasons (possibility of boiling over).

IN CASE OF FAILURE TO COMPLY WITH THE ABOVE CONDITIONS, THE CUSTOMER WILL LOSE THE RIGHT TO WARRANTY SERVICE.

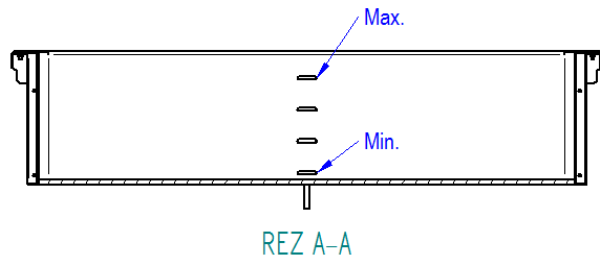
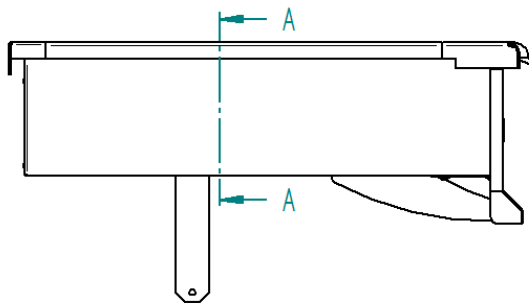

HOW TO CARE FOR A CAST IRON BOTTOM OF COOKING TANK?

As the name suggests, the bottom of the cooking tank is made of cast iron, a material that is characterized by high resistance, long life and excellent thermal conductivity. Compared to other materials, it does not have any materials of various chemical compounds on its surface. Due to this fact, the cooking tank is resistant even at high temperatures and does not release any toxic substances.

Before you start using the tilting bratt pan, it is necessary to burn the cooking tank.

The procedure is as follows:

1. First, thoroughly coat the cooking tank on all sides with cooking oil, preferably sunflower oil.
2. Turn on the bratt pan to 150 ° C degrees and leave it on for at least 20 minutes until all the oil has burned off. This procedure of burning the cooking tank is the source of a strong smell of burnt oil, so it is necessary to ventilate well.
3. After switching off, let the cooking tank cool down and only then can you wipe off the excess oil.

The tilting bratt pan burned in this way is ready for use. After use, you do not need to burn the pan again, just clean it with hot water without detergent and dry it thoroughly. After wiping the pan dry, apply a thin layer of cooking oil to the bottom of the cooking tank to prevent unpleasant corrosion.

If the cooking tank starts to rust after some time, don't worry, remove the rust with a soft brush and fire it again. **DO NOT USE DETERGENT** under any circumstances - this will remove the surface fat layer that forms a non-stick surface on the dishes. Water-based cooking is forbidden (cooking dumplings, steamed buns, etc.), ALWAYS START COOKING WITH OIL.

10. Safety features

The Gastro-Haal electric equipment from the Practic product line contains the following safety features:

- **limit microswitch** - if the equipment is not in the working position (the cooking tank is tilted), the microswitch disables the heating elements and the water filling.

- **safety thermostat**

The required temperature is regulated by a working thermostat, which can be set to a temperature in the range from 50 °C to 250 °C.

11. Safety instructions

- It is forbidden to pour hot oil out of the cooking tank!
- In the event of oil ignition in the cooking tank, the lid must be closed immediately and not opened!
- Be extra careful when operating. The surface of the equipment is hot, especially the edges of the cooking tank!

THE EQUIPMENT MUST NOT BE USED AS A FRYER! IMPROPER HANDLING COULD CAUSE OIL IN THE COOKING TANK TO IGNITE!

12. Maintenance and cleaning of the equipment

WARNING!

Before cleaning and maintenance, it is necessary to turn off the equipment from the electrical network. The equipment must not be cleaned with water spray!!!

After the end of daily operation, the equipment must be thoroughly washed with lukewarm water with neutral detergent and wiped dry. It is necessary to ensure that the parts being cleaned (inside the cooking tank) are cooled down. Do not use washing powders or cleaning detergents that can damage these parts on stainless steel parts. Avoid detergents containing a high concentration of chlorine, which can cause corrosion of stainless steel material (top plate, cooking tank and lid). Therefore, before using such a product, you should carefully read its composition and instructions for use. We recommend washing the cooking tank with ordinary detergents. Sandpaper and wire brushes must not be used for cleaning. For larger dirt, a synthetic sponge should be used.

Stainless steel can also rust due to the ingress of metal impurities through the water supply, chlorine levels in the service water exceeding 2 mg/l, due to a higher salt concentration, pH outside the range of 7.2-7.6, or due to contact with other materials (e.g. copper) or due to the incorrect choice of detergent.

IN CASE OF FAILURE TO COMPLY WITH THE ABOVE CONDITIONS, THE CUSTOMER WILL LOSE THE RIGHT TO WARRANTY SERVICE.

When the pan is out of service for a long time, we recommend coating the cooking tank with **edible oil!!!**

For the treatment of GASTRO-HAAL equipment, the manufacturer recommends using TIEFFE brand cleaning agents, which are specially tested, proven and suitable by the manufacturer.

13. Connection dimensions

P.PE-750 C

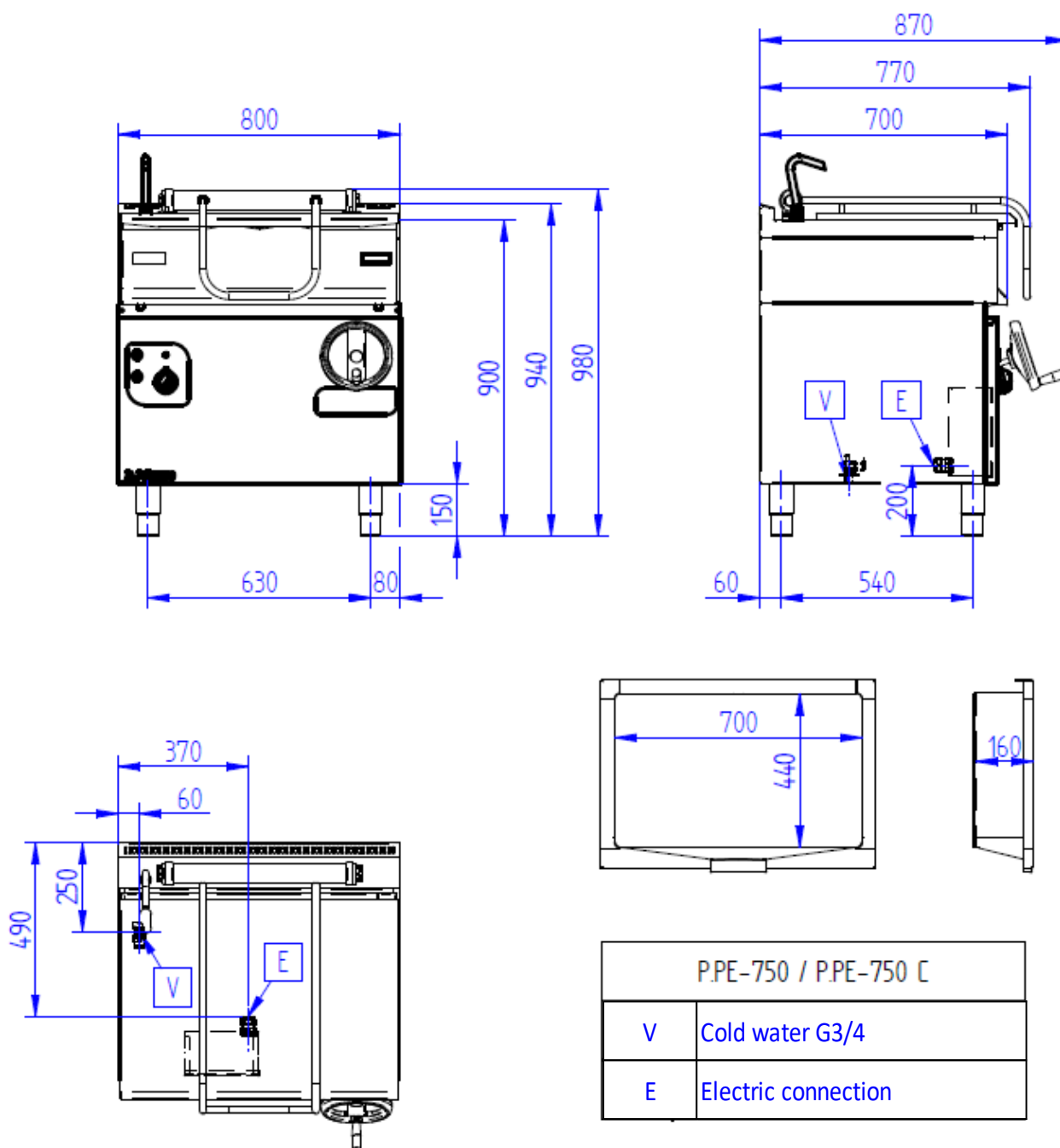

P.PE-980 C

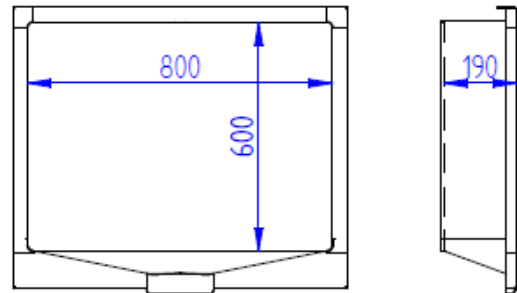
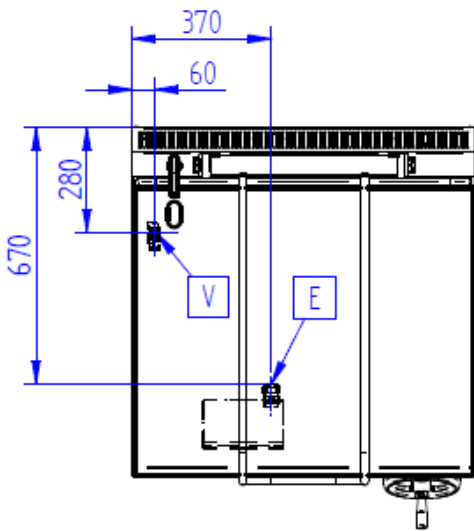
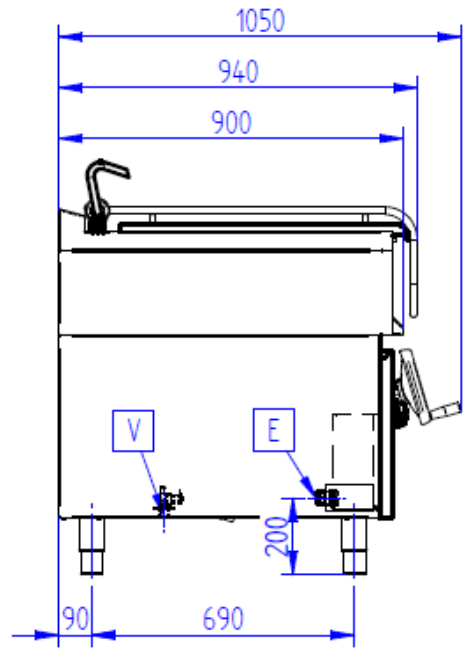
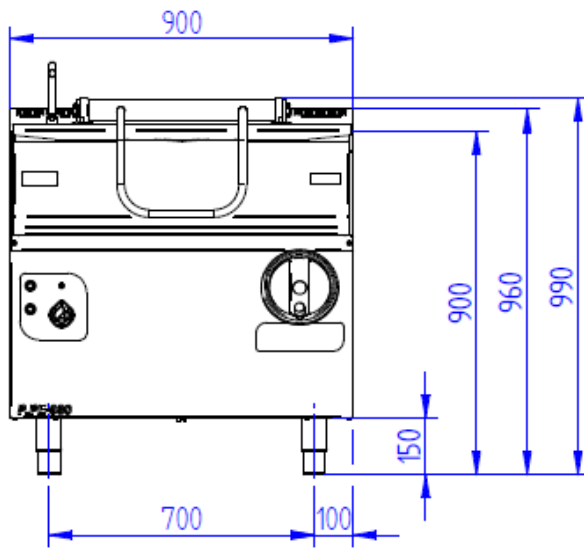

P.PE-980 / P.PE-980 C	
V	Cold water G3/4
E	Electric connection

P.PE-9120 C

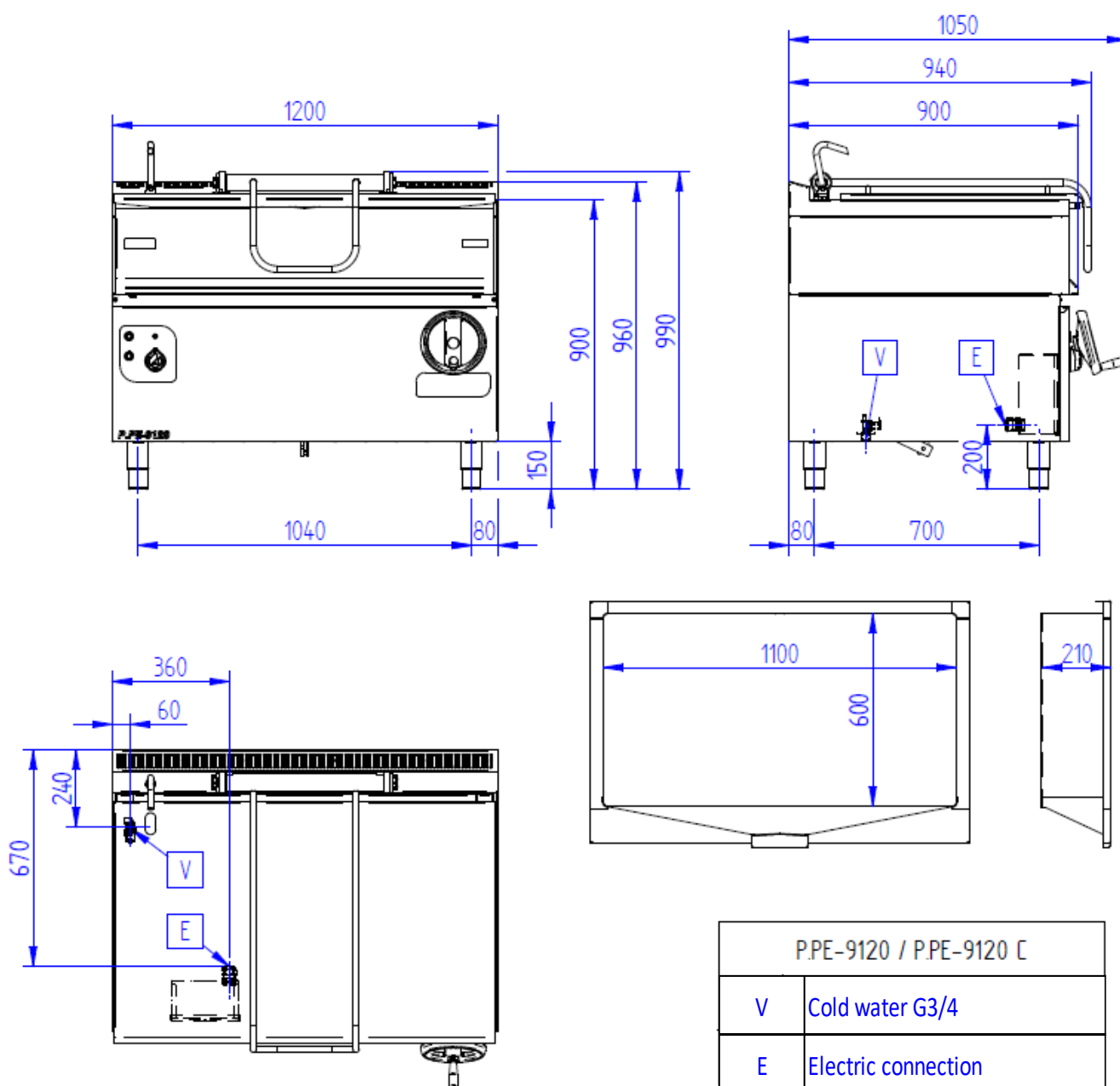

P.PE-9120 / P.PE-9120 C	
V	Cold water G3/4
E	Electric connection

14. Electrical wiring diagram

P.PE-750 C

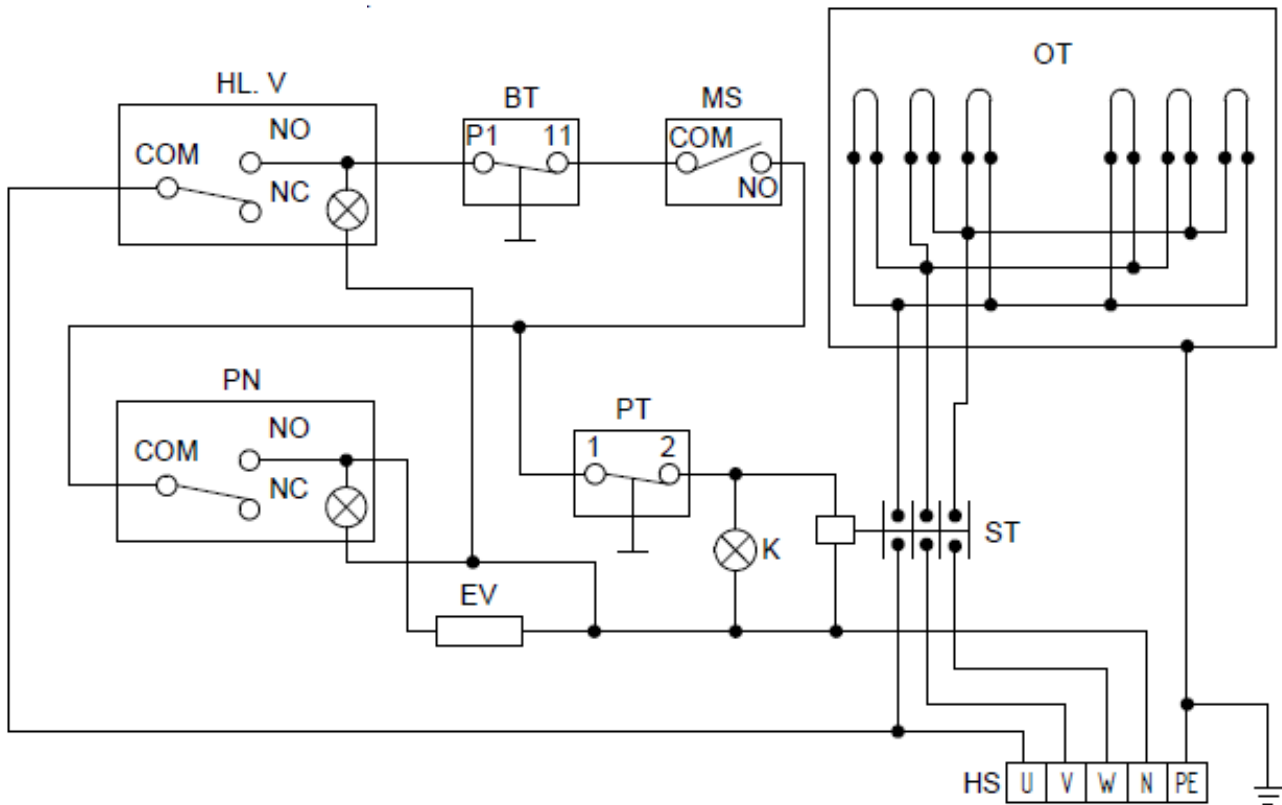

Legend:

- HL.V – main switch
- PN – water filling switch
- EV – electromagnetic valve
- PT – working thermostat
- ST – contactor
- OT – heating elements
- MS – microswitch
- K – heating indicator light
- HS – main terminal block
- BT – safety thermostat

P.PE-980

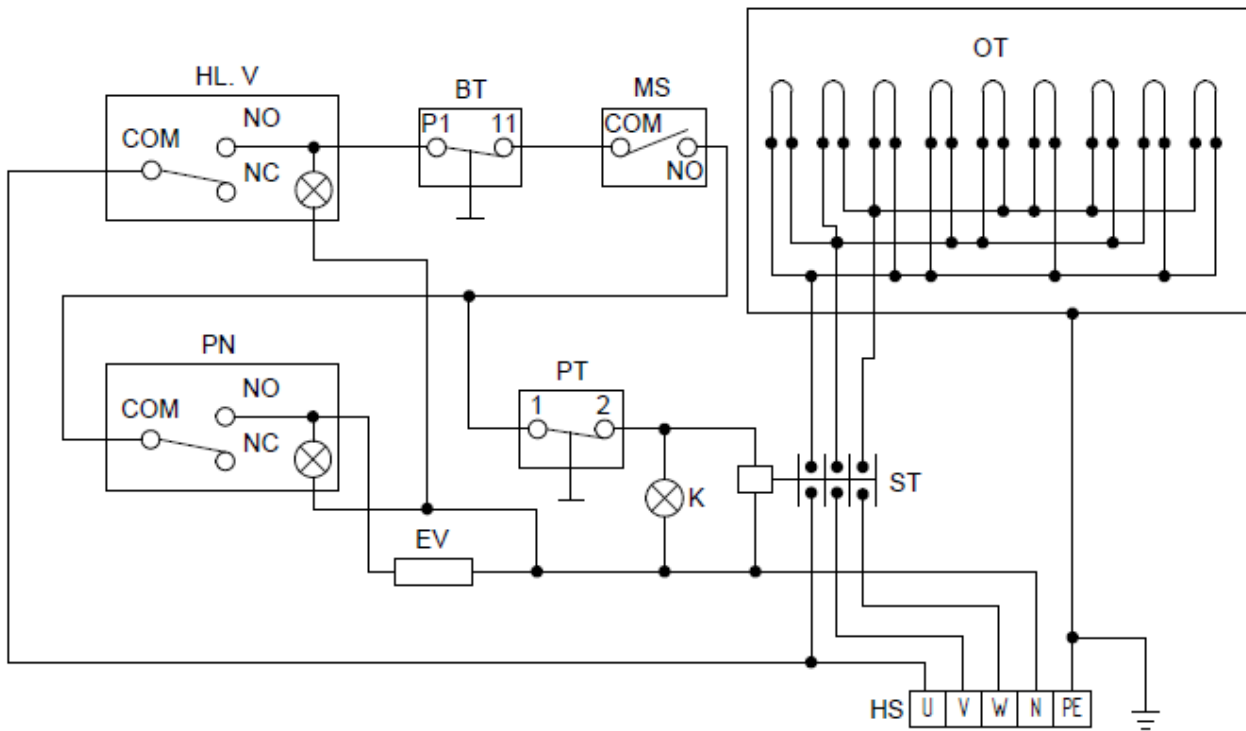

Legend:

- HL.V – main switch
- PN – water filling switch
- EV – electromagnetic valve
- PT – working thermostat
- ST – contactor
- OT – heating elements
- MS – microswitch
- K – heating indicator light
- HS – main terminal block
- BT – safety thermostat

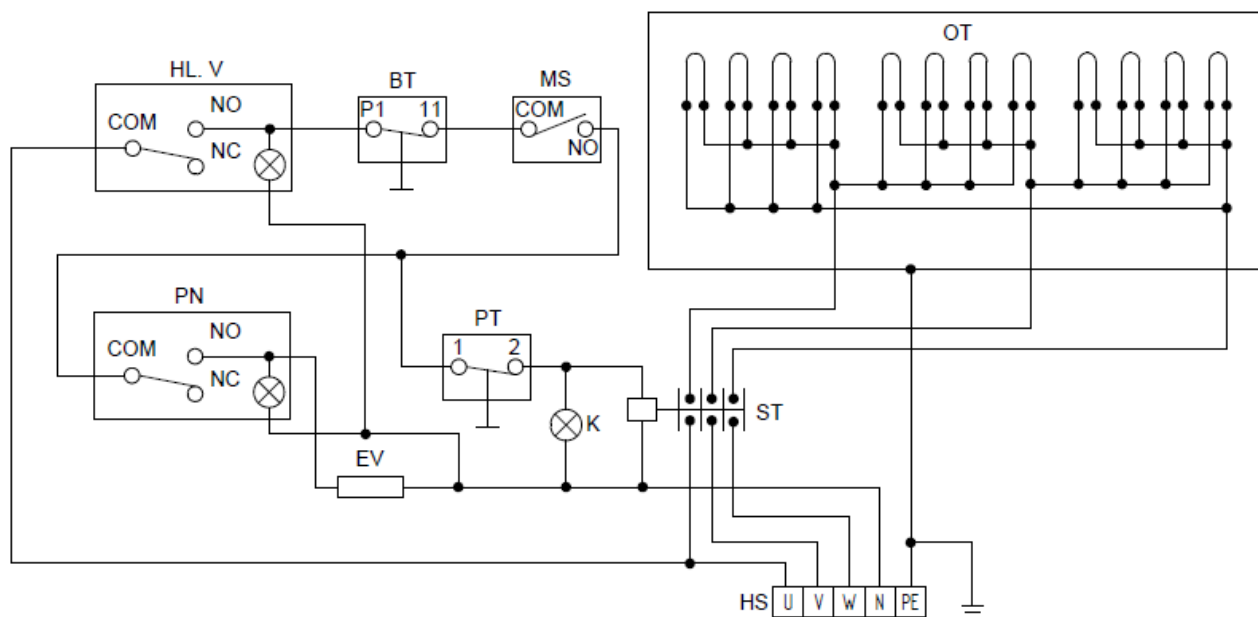

Legend:

- HL.V – main switch
- PN – water filling switch
- EV – electromagnetic valve
- PT – working thermostat
- ST – contactor
- OT – heating elements
- MS – microswitch
- K – heating indicator light
- HS – main terminal block
- BT – safety thermostat

SUPPLIER:

(add the contact details)

SERVICE TECHNICIAN:

(add the contact details)

MANUFACTURER

GASTRO – HAAL, s.r.o. Povazska 16, 940 67 Nove Zamky, SR +421 35 6 430 115 gastro@gastrohaal.sk
Company ID: 31435076 VAT ID: 2020413659 VAT ID: SK2020413659 www.gastrohaal.sk/en