



Gastro-Haal

USER MANUAL

for installation and maintenance

BOILING PANS

electric with automatic water refilling

Practic

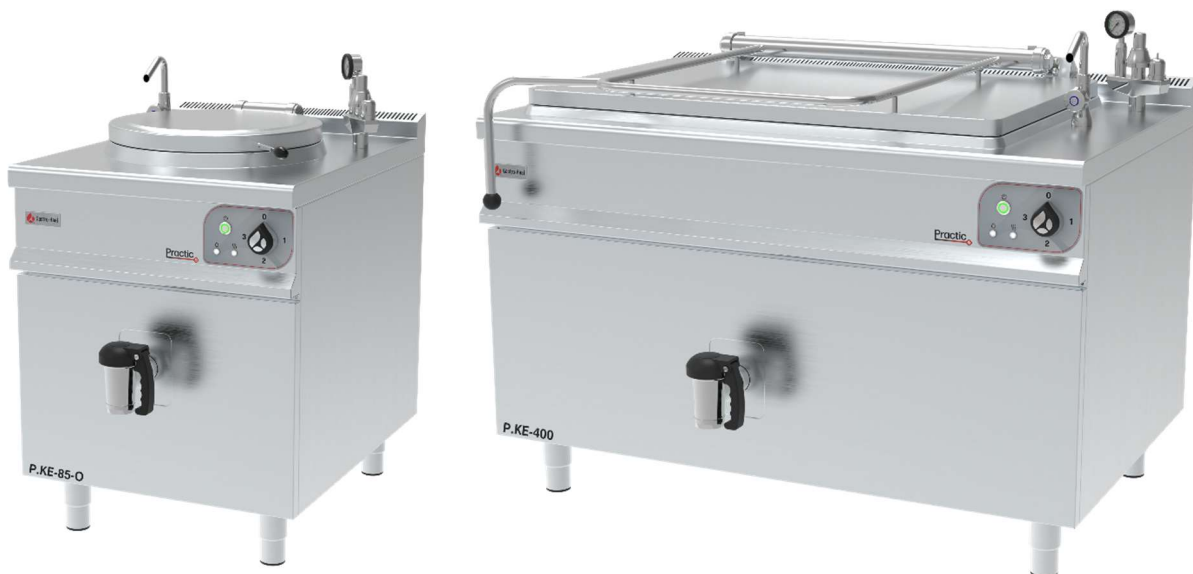

PRODUCT LINE:

PRACTIC

ROUND DUPLICATOR

P.KE-785-O, P.KE-85-O, P.KE-100-O, P.KE-150-O

SQUARE DUPLICATOR

P.KE-100, P.KE-150, P.KE-200, P.KE-300, P.KE-400, P.KE-500

Issued: 11/2024

CE ₁₂₉₉

Content

1. General information	3
2. Use	3
3. Safety regulations.....	3
4. Legal regulations.....	3
5. Technical data	5
6. Description of boiling pans.....	10
7. Installation	11
8. Operation	11
9. Maintenance and cleaning of the equipment	16
10. Important instructions.....	16
11. Boiling pan location	17
12. Attachments.....	18
12.1. Safety valve	18
12.2. Connection dimensions	19
12.3. Electric wiring diagram	29
13. Instructions for use of the outlet valve.....	35

The contact details of the supplier and service provider can be found on page 36.



<https://gastrohaal.sk/en/product-registration>

1. General information

Dear user, thank you for choosing our product. Please read these operating instructions carefully before using the equipment so that the equipment can serve you to your satisfaction.

2. Use

The Gastro-Haal equipment from the Practic product line is a basic unit in large-scale kitchens - restaurants, hospitals, factory and school canteens, and military units...

It is used in butchery, charcuterie, fruit preservation, etc. It is used for cooking soups, sauces, meat, pasta, dairy dishes without the risk of burning, for stewing fish, vegetables, mushrooms, for heating frozen foods or semi-finished products...

Cooking tank of boiling pans P.KE-100, P.KE-150, P.KE-200, P.KE-300 a P.KE-400, P.KE-500 is square and thus allows cooking, stewing and heating using containers according to the Gastro-norm dimensional range. Boiling pans P.KE-785-O, P.KE-85-O, P.KE-100-O, P.KE-150-O have round cooking tank.

3. Safety regulations

The manufacturer declares that the equipment are in compliance with the regulations and applicable decrees of the European Union and the relevant government regulations.

Attention! The manufacturer disclaims any liability in the event of direct and indirect damages related to improper installation, improper assembly or other causes.

The equipment must only be operated by qualified persons. Parts set by the manufacturer or a specialist service are strictly prohibited for the user to rebuild. It is forbidden to touch any parts of the equipment other than those specified by the control and manufacturer during operation. Furthermore, it is forbidden to clean and wash the equipment during operation. It is forbidden to use the equipment for any purpose other than that specified in the manual. Maintenance and repair can only be carried out when the equipment is switched off from the mains. The equipment may only be used to cook food in water and milk.

Inspection by service personnel designated by the manufacturer once a year is recommended. When replacing spare parts, original spare parts must be used.

The manufacturer is not responsible for defects caused by improper installation and operation.

4. Legal regulations

CUSTOMER WHO HAS BEEN ASSEMBLED, ADJUSTED AND REPAIRED BY AN ORGANISATION NOT AUTHORISED BY THE MANUFACTURING ORGANISATION CANNOT CLAIM THE COSTS ASSOCIATED WITH THE WARRANTY REPAIR WITH THE MANUFACTURER.

The operator using the electric boiling pan must read the Installation and Maintenance Instructions in detail. Furthermore, the person responsible for the buyer is obliged to participate, together with the operating staff, in professional training in accordance with the document Operation and Maintenance Protocol, which is an annex to the Installation and Maintenance Instructions and is required to be confirmed by the signature of the responsible person and the buyer's stamp. Professional training according to the above takes place during the installation / assembly of the equipment by an authorized service technician. In the event of improper use and operation of the boiling pan, the right to warranty repair is lost!!!

The manufacturer will provide a warranty for the boiling pan according to the enclosed " Warranty certificate".

Outlet valve seals are not covered by the warranty!

Defects that can be rectified by the user are not considered to be defects subject to warranty.

Defects covered by the warranty will be repaired by the manufacturer's service organization or its representative.

Warning!

THE MANUFACTURER IS NOT RESPONSIBLE FOR THE INCORRECT TECHNOLOGICAL PROCEDURE OF THE OPERATOR DURING COOKING.

5. Technical data

Line	700	900	900	900	900	900
Type	P.KE-785-O	P.KE-85-O	P.KE-100-O	P.KE-150-O	P.KE-100	P.KE-150
Product line	Practic	Practic	Practic	Practic	Practic	Practic
Equipment	electric boiling pan	electric boiling pan	electric boiling pan	electric boiling pan	electric boiling pan	electric boiling pan
Control panel	classic analogy	classic analogy	classic analogy	classic analogy	classic analogy	classic analogy
External dimensions (mm) wxdxh	700x700x900 mm	700x900x900 mm	900x900x900 mm	900x900x900 mm	900x900x900 mm	900x900x900 mm
Volume of cooking tank (l)	93 l	93 l	106 l	154,4 l	138,7 l	168,7 l
Useful volume of cooking tank (max. scale) (l)	85 l	85 l	95 l	143,1 l	100 l	150 l
Weight	90 kg	100 kg	123 kg	130 kg	140 kg	140 kg
Duplicator	round	round	round	round	square	square
Duplicator volume (in intermediate jacket) (l)	39,8 l	39,8 l	48,5 l	51,7 l	55,3 l	57,4 l
Water volume in duplicator (after level sensor) (l) * Increased water volume in the duplicator ensures longer service life of the heating elements	20,8 l	20,8 l	37,3 l	36 l	29,5 l	29,4 l
Automatic filling of water into duplicator	yes	yes	yes	yes	yes	yes
Nominal pressure of duplicator (bar)	0,4 bar	0,4 bar	0,4 bar	0,4 bar	0,4 bar	0,4 bar
Steam temperature in intermediate jacket at pressure 0,4 bar	109,7 °C	109,7 °C	109,7 °C	109,7 °C	109,7 °C	109,7 °C
Heating						
Heating elements in special steel box under duplicator – indirect heating	yes	yes	yes	yes	yes	yes
Heating elements material for higher resistance against overheating	AISI 316	AISI 316	AISI 316	AISI 316	AISI 316	AISI 316
Max. input (kW)	12 kW	12 kW	12 kW	18 kW	12 kW	18 kW

Type	P.KE-785-O	P.KE-85-O	P.KE-100-O	P.KE-150-O	P.KE-100	P.KE-150
Nominal voltage (V)	3x400/230 V + PEN 50 Hz TN-S	3x400/230 V + PEN 50 Hz TN-S	3x400/230 V + PEN 50 Hz TN-S	3x400/230 V + PEN 50 Hz TN-S	3x400/230 V + PEN 50 Hz TN-S	3x400/230 V + PEN 50 Hz TN-S
Nominal current (A)	17 A	17 A	17 A	26 A	17 A	26 A
Circuit breaker (A)	20 A	20 A	20 A	32 A	20 A	32 A
Three-stage power regulation of heating elements with 4-position switch	yes	yes	yes	yes	yes	yes
Water heating time in a cooking tank 20-90 °C (min.)	52 min	52 min	47 min	55 min	47 min	55 min
Water, valve, protection						
Cold water connection to cooking tank (")	3/4 "	3/4 "	3/4 "	3/4 "	3/4 "	3/4 "
Cold untreated water connection to duplicator (")	3/4 "	3/4 "	3/4 "	3/4 "	3/4 "	3/4 "
Max. water pressure (bar)	6 bar	6 bar	6 bar	6 bar	6 bar	6 bar
Outlet valve (")	2"	2"	2"	2"	2"	2"
Tube to outlet valve (")	2"	2"	2"	2"	2"	2"
Index IP	IP 41	IP 41	IP 41	IP 41	IP 41	IP 41
Index IP control elements	IP 65	IP 65	IP 65	IP 65	IP 65	IP 65
Construction, saving, safety						
Material of top plate	AISI 304	AISI 304	AISI 304	AISI 304	AISI 304	AISI 304
Material of outer part of duplicator	AISI 321 titanium reinforced material	AISI 321 titanium reinforced material	AISI 321 titanium reinforced material	AISI 321 titanium reinforced material	AISI 304	AISI 304
Material of lid	AISI 304	AISI 304	AISI 304	AISI 304	AISI 304	AISI 304
Material cooking tank	AISI 316	AISI 316	AISI 316	AISI 316	AISI 316	AISI 316
Bottom covering	yes	yes	yes	yes	yes	yes
Rounded edges without danger corners and protrusion	yes	yes	yes	yes	yes	yes
Pressed top plate for water outfall	no	no	yes	yes	no	no
Thermal and protective insulation of duplicator with high resistance to heat, fire, alcohol	yes	yes	yes	yes	yes	yes

Type	P.KE-785-O	P.KE-85-O	P.KE-100-O	P.KE-150-O	P.KE-100	P.KE-150
Double insulation on cables and wires (silicone protection)	yes	yes	yes	yes	yes	yes
2 probes (min/max) for measuring water level in duplicator with AISI 316 material for more reliable measurement and longer service life	yes	yes	yes	yes	yes	yes
Liter capacity on internal side of cooking tank	30l, 55l, 85l	30l, 55l, 85l	30l, 65l, 100l	30l, 60l, 90l,120l,150l	50l, 100l	50l, 100l, 150l
Manually opening, the lid placed in cold zone, handle from side of boiling pan	yes, up to 90°	yes, up to 90°	yes, up to 90°	yes, up to 90°	yes, up to 80°	yes, up to 80°
Safety valve	yes	yes	yes	yes	yes	yes
Tap for cold and hot water	yes	yes	yes	yes	yes	yes
Sieve in front of outlet valve	yes	yes	yes	yes	yes	yes
Adjustable feet	yes	yes	yes	yes	yes	yes
Options for extra fees according of valid price list						
2x water connections + tap for hot and cold water 3/4 "	yes (extra fee)	yes (extra fee)	yes (extra fee)	yes (extra fee)	yes (extra fee)	yes (extra fee)
Index IP45	yes (extra fee)	yes (extra fee)	yes (extra fee)	yes (extra fee)	yes (extra fee)	yes (extra fee)
Vaseline for outlet valve	yes (extra fee)	yes (extra fee)	yes (extra fee)	yes (extra fee)	yes (extra fee)	yes (extra fee)
Cooking baskets	yes (extra fee)	yes (extra fee)	yes (extra fee)	yes (extra fee)	yes (extra fee)	yes (extra fee)
Steamers	yes (extra fee)	yes (extra fee)	yes (extra fee)	yes (extra fee)	yes (extra fee)	yes (extra fee)
Dumpling strainers	yes (extra fee)	yes (extra fee)	yes (extra fee)	yes (extra fee)	yes (extra fee)	yes (extra fee)
Water softener (filter cartridge)	yes (extra fee)	yes (extra fee)	yes (extra fee)	yes (extra fee)	yes (extra fee)	yes (extra fee)

Line	900	900	900	900
Type	P.KE-200	P.KE-300	P.KE-400	P.KE-500
Product line	Practic	Practic	Practic	Practic
Equipment	electric boiling pan	electric boiling pan	electric boiling pan	electric boiling pan
Control panel	classic analogy	classic analogy	classic analogy	classic analogy
External dimensions (mm) wxdxh	1400x900x900 mm	1400x900x900 mm	1400x900x900 mm	1800x900x900 mm
Volume of cooking tank (l)	257,6 l	342,4 l	416,3 l	572,9 l
Useful volume of cooking tank (max. scale) (l)	200 l	300 l	376 l	500 l
Weight	185 kg	195 kg	255 kg	280 kg
Duplicator	square	square	square	square
Duplicator volume (in intermediate jacket) (l)	90 l	94,2 l	110 l	138,4 l
Water volume in duplicator (after level sensor) (l) * Increased water volume in the duplicator ensures longer service life of the heating elements	46,2 l	46,1 l	58 l	67,7 l
Automatic filling of water into duplicator	yes	yes	yes	yes
Nominal pressure of duplicator (bar)	0,4 bar	0,4 bar	0,4 bar	0,4 bar
Steam temperature in intermediate jacket at pressure 0,4 bar	109,7 °C	109,7 °C	109,7 °C	109,7 °C
Heating				
Heating elements in special steel box under duplicator – indirect heating	yes	yes	yes	yes
Heating elements material for higher resistance against overheating	AISI 316	AISI 316	AISI 316	AISI 316
Max. input (kW)	24 kW	30 kW	36 kW	42 kW
Nominal voltage (V)	3x400/230 V + PEN 50 Hz TN-S	3x400/230 V + PEN 50 Hz TN-S	3x400/230 V + PEN 50 Hz TN-S	3x400/230 V + PEN 50 Hz TN-S
Nominal current (A)	34 A	44 A	52 A	63 A
Circuit breaker (A)	40 A	50 A	80 A	100 A
Three-stage power regulation of heating elements with 4-position switch	yes	yes	yes	yes
Water heating time in a cooking tank 20-90 °C (min.)	61 min	69 min	75 min	85 min
Water, valve, protection				
Cold water connection to cooking tank (")	3/4 "	3/4 "	3/4 "	3/4 "

Type	P.KE-200	P.KE-300	P.KE-400	P.KE-500
Cold untreated water connection to duplicator (")	3/4 "	3/4 "	3/4 "	3/4 "
Max. water pressure (bar)	6 bar	6 bar	6 bar	6 bar
Outlet valve (")	2"	2"	2"	2"
Tube to outlet valve (")	2"	2"	2"	2"
Index IP	IP 41	IP 41	IP 41	IP 41
Index IP control elements	IP 65	IP 65	IP 65	IP 65
Construction, saving, safety				
Material of top plate	AISI 304	AISI 304	AISI 304	AISI 304
Material of outer part of duplicator	AISI 304	AISI 304	AISI 304	AISI 304
Material of lid	AISI 304	AISI 304	AISI 304	AISI 304
Material cooking tank	AISI 316	AISI 316	AISI 316	AISI 316
Bottom covering	yes	yes	yes	yes
Rounded edges without danger corners and protrusion	yes	yes	yes	yes
Pressed top plate for water outfall	no	no	no	no
Thermal and protective insulation of duplicator with high resistance to heat, fire	yes	yes	yes	yes
Double insulation on cables and wires (silicone protection)	yes	yes	yes	yes
2 probes (min/max) for measuring water level in duplicator with AISI 316 material for more reliable measurement and longer service life	yes	yes	yes	yes
Liter capacity on internal side of cooking tank	100l,150l,200l	100l, 133l, 166l, 200l, 233l, 266l, 300l	100l, 150l, 200l, 250l, 300l, 350l, 400l	100l, 150l, 200l, 250l, 300l, 350l, 400l, 450l, 500l
Manually opening, the lid placed in cold zone, handle from side of boiling pan	yes, up to 80°	yes, up to 80°	yes, up to 80°	yes, up to 80°
Safety valve	yes	yes	yes	yes
Tap for cold water	yes	yes	yes	yes
Sieve in front of outlet valve	yes	yes	yes	yes
Adjustable feet	yes	yes	yes	yes
Options for extra fees according of valid price list				
2x water connections + tap for hot and cold water 3/4 "	yes (extra fee)	yes (extra fee)	yes (extra fee)	yes (extra fee)
Index IP45	yes (extra fee)	yes (extra fee)	yes (extra fee)	yes (extra fee)
Vaseline for outlet valve	yes (extra fee)	yes (extra fee)	yes (extra fee)	yes (extra fee)
Cooking baskets	yes (extra fee)	yes (extra fee)	yes (extra fee)	yes (extra fee)
Steamers	yes (extra fee)	yes (extra fee)	yes (extra fee)	yes (extra fee)
Dumpling strainers	yes (extra fee)	yes (extra fee)	yes (extra fee)	yes (extra fee)
Water softener (filter cartridge)	yes (extra fee)	yes (extra fee)	yes (extra fee)	yes (extra fee)

6. Description of boiling pans

Characteristics:

- automatic water supply to the duplicator
- rapid heating of cooking tank
- easy operation - automatic operation
- minimal maintenance
- low operating costs
- quiet, safe, noiseless operation
- suitable for places without a gas connection

Indirect heating is designed for rapid boiling and maintaining temperature. Cooking with a duplicator ensures even heating, food does not burn or overcook - cooking procedures are in accordance with ecological food processing.

The boiling pan consists of the following basic parts:

- self-supporting construction
- its own cooking tank with a duplicator
- heating element system 3x2000 W, 230 V
- external side covers

The boiling pan construction is self-supporting. The upper part of the boiling pan and the lower part are connected by side panels. The side panels are attached with screws at the top and bottom. The external covers such as the control panel, front cover and rear cover are screwed. The cooking tank is square (P.KE-100, P.KE-150, P.KE-200, P.KE-300, P.KE-400, P.KE-500) or round (P.KE-785-O, P.KE-85-O, P.KE-100-O, P.KE-150-O).

The cooking tank has duplicator with a closed steam space. In the lower part there is a space for heating elements.

The boiling pan is made of food-safe stainless steel material and with duplicator, so heat is supplied to the cooked food from the heating elements via steam, which is generated inside the double jacket.

The basic part consists of a duplicator placed on a self-supporting construction. It is equipped with a safety valve that protects it from excessive overpressure and at the same time ensures its venting before the start of cooking and its re-venting after the end of cooking. This valve also includes a dial pressure gauge that allows you to simultaneously check the pressure in the duplicator. The boiling pan is equipped with a pressure switch with a maximum working pressure of 400 mbar (0.4 bar).

The boiling pan is made of stainless steel, consists of a top plate with a self-supporting construction equipped with four adjustable feet.

The required power can be set using the four-position heating power switch. The switching on and off of the heating elements during operation is controlled by the control circuit.

The outlet valve 2" is used to drain the contents of the duplicator's cooking space. At the beginning of heating, the steam from the duplicator pushes the air out through the vent valve of the combined safety valve. The accelerating steam flow closes the valve, thus creating a closed space. As a result of the constant heating, an overpressure is created, which is signaled by the pressure gauge. After the heating is switched off, the steam pressure gradually decreases due to the continuous heat dissipation.

When it reaches a value of about 0.3 bar, the pressure switch switches on the boiling pan the heating corresponding to the set position of the power control switch. Level 3 corresponds to the maximum power of the heating elements.

To maintain a constant temperature, you can select position 1 or 2 on the switch.

The basic condition for reliable operation of the boiling pan is that the heating elements are always submerged under water. To ensure this condition, a water level sensor (max. - min.) is installed in the equipment. If the level drops below the minimum height, it automatically prevents further heating.

The fact that the water level has dropped below the minimum level is indicated by the indicator light marked with the control. After this indicator light is lit, automatic water addition is started.



7. Installation

The connection and installation of the boiling pan can only be carried out by an organization or person authorized by the manufacturer for the above work.

- The electric boiling pan must be mounted on a fixed, revised electrical wiring.
- A main switch must be installed between the equipment and the distribution network, which must be near the equipment.
- The voltage in the electrical network must match the voltage indicated in the technical table.
- The connection must be made in accordance with standards and local regulations according to the electrical wiring diagram.
- The supply terminal block can be accessed after removing the front panel.
- The equipment must be grounded. There is a grounding cable eyelet on the foot of the equipment, which must be connected to the connecting grounding system.
- The electric boiling pan must be connected to a separate line from the main switchboard.
- The boiling pan must be set to a horizontal position.
- We recommend installing the boiling pan on place with a waste channel.
- The boiling pan is adapted for connection of cold water with flexible hoses, resistant to the pressure in the pipe network, max. however 6 bar. If this pressure in the network is higher, a pressure regulator must be installed before connecting the equipment!!! The hoses must meet the hygienic requirements for contact with drinking water. The supplied water should not be too hard (hardness of 4.4-5.6 German degrees is recommended), otherwise the efficiency of the boiling pan is reduced due to deposits on the duplicator. For hardness above 5.6 German degrees, we recommend using a water softener.
- If the protective film has not been removed, it must be removed. Before first use, it is necessary to remove the protective film from the outlet valve sieve.

8. Operation

Switching on, operating, turning off the equipment

It is necessary to turn on the main switch located outside the boiling pan. Open the filling valve (tap on the top of the boiling pan) and fill the cooking tank with water.

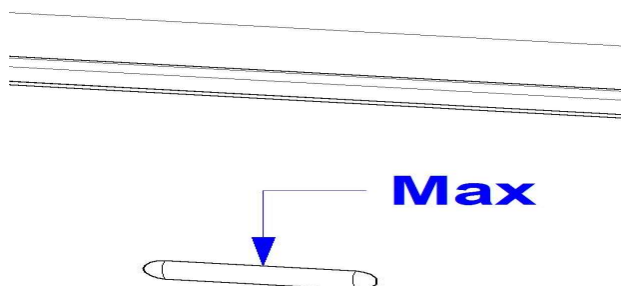

Liters of boiling pans Practic.

Fill the cooking tank only to the line that indicates the **maximum filling limit**. If filled above this limit, boiling may occur and may cause injury.

P.KE-785-O / P.KE-85-O

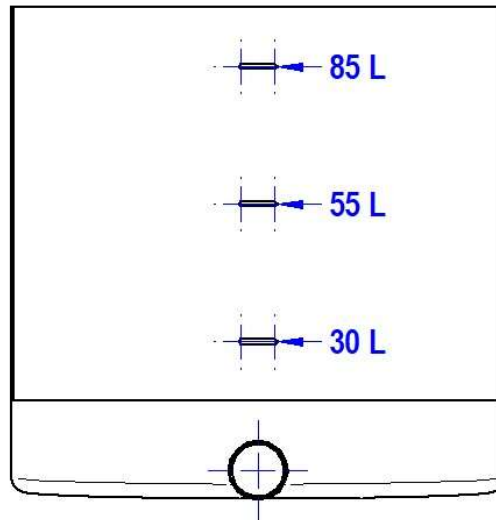

P.KE-100

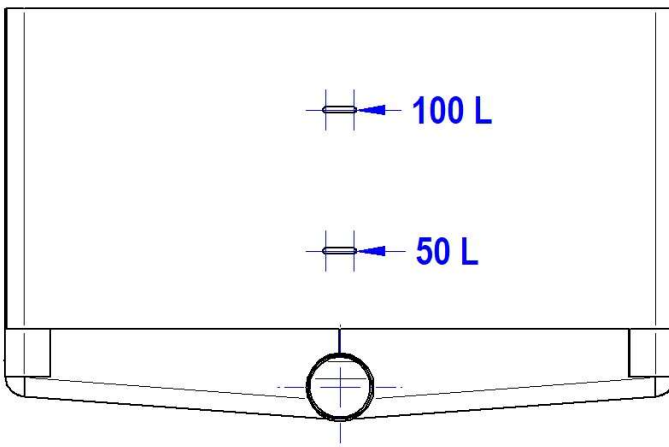

P.KE-100-O

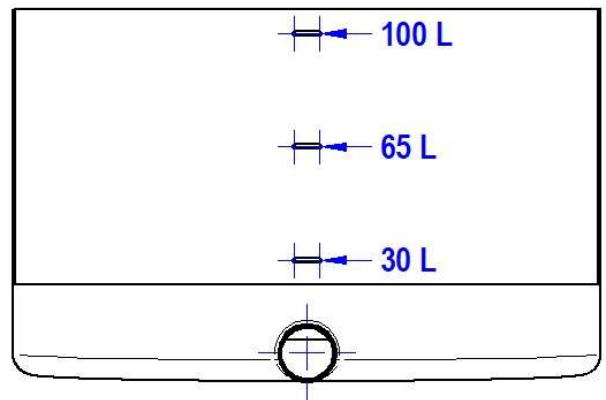

P.KE-150

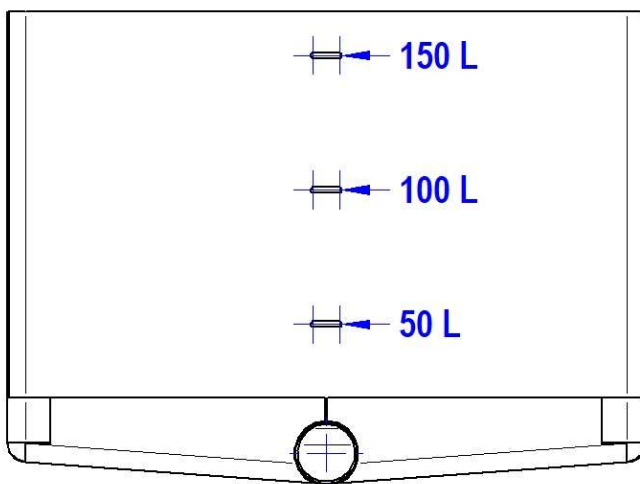

P.KE-150-O

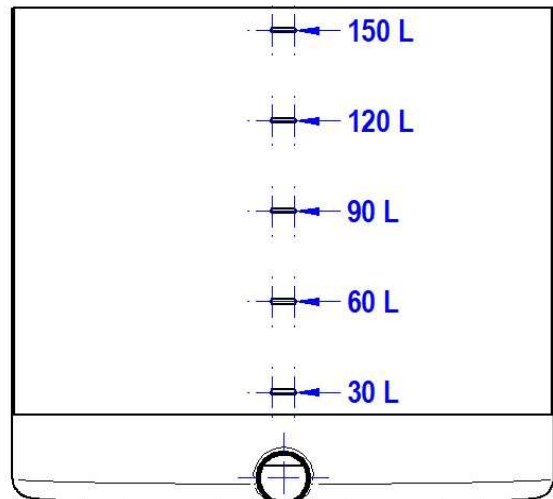

P.KE-200

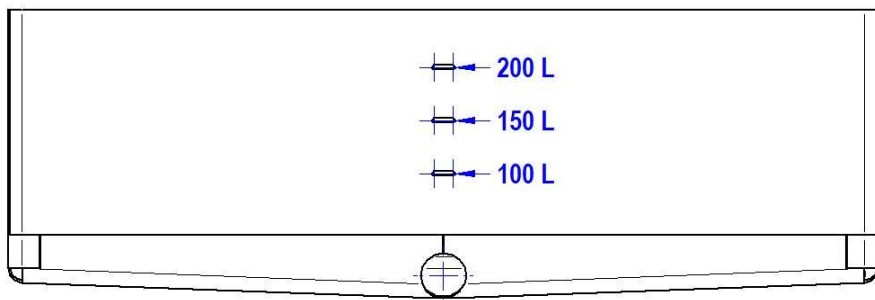

P.KE-300

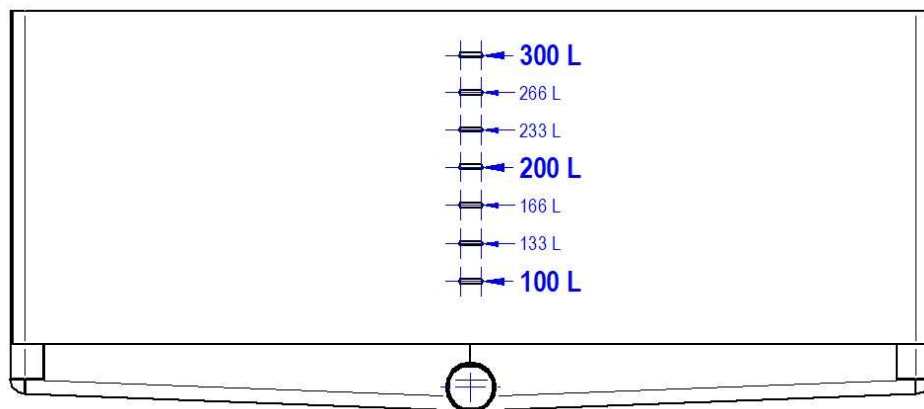

P.KE-400

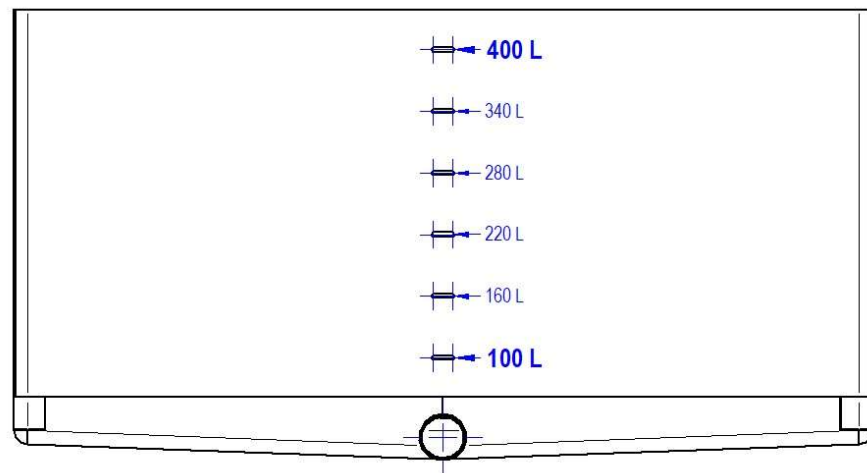

P.KE-500

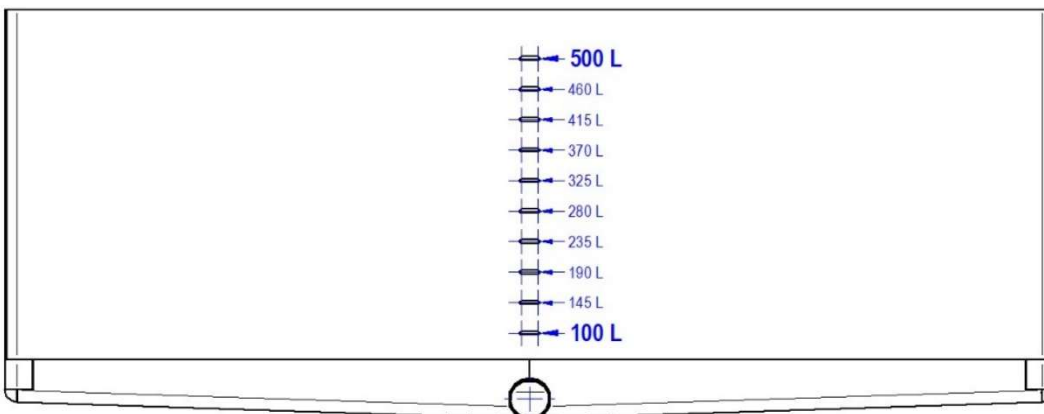



Turn on the main switch. **If there is not enough water in the duplicator, the indicator light will switch on and the water will start to fill the duplicator.** During the filling, the operation of the heating elements is stopped. The filling of water is automatic, controlled by the control circuit. When the required amount of water is in the duplicator, the indicator light will stop - the filling is complete, and the boiling pan will start operating.

Turn on the power control knob to level 3. The operation of the heating elements is signaled by the **indicator**



light. After turning on the heating elements, it is necessary to monitor the pressure on the safety valve.

Control panel consists of:

	<p>1. Main rotary knob - rotary knob for setting the heating power 0-1-2-3 3 levels of heating power 0 = no heating 1 = minimum power 2 = half power 3 = full power</p>
	<p>2. Main switch - control of electricity ON/OFF - green light signals that equipment is in operation</p>
	<p>3. Heating light - control light signals the heating - switching on the heating elements to operation</p>
	<p>4. Water filling light - control light signals the filling water into duplicator</p>

Picture: **Control panel of electric boiling pan Practic:**

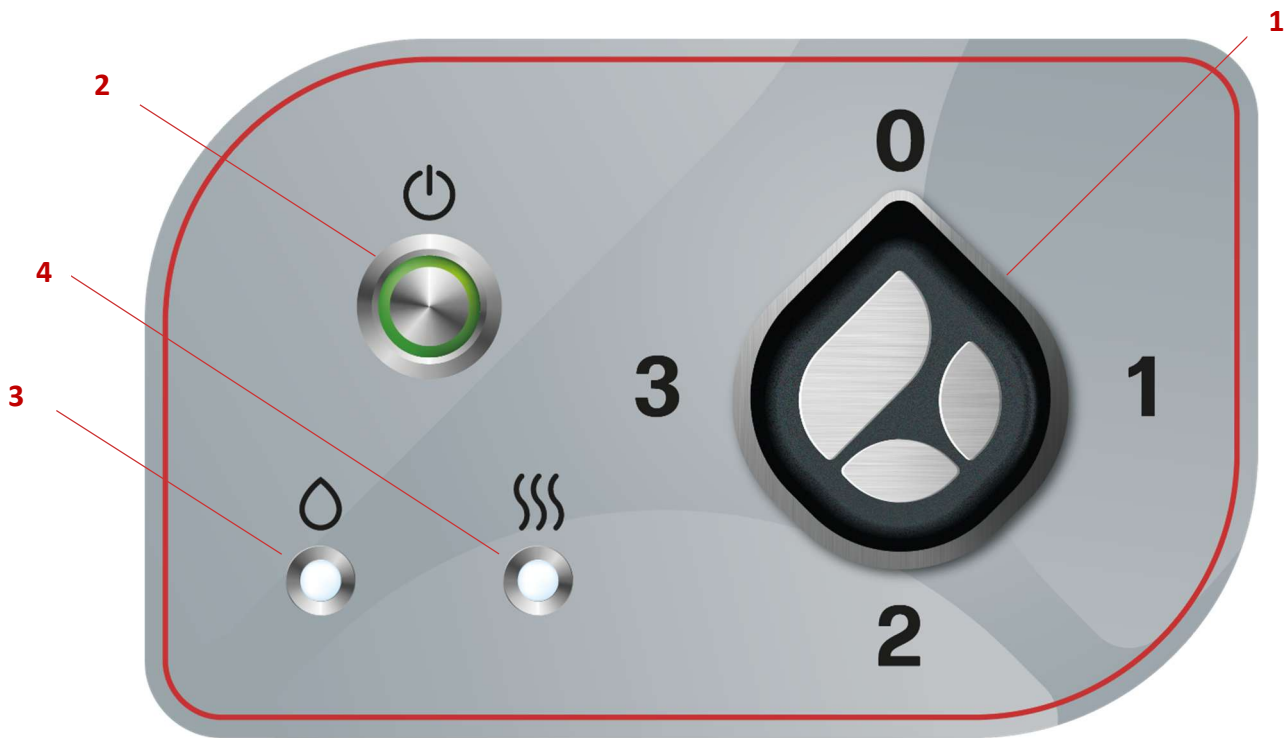

- 1 = Rotary knob for setting the heating power**
- 2 = Main switch**
- 3 = Duplicator water filling light**
- 4 = Heating light**

Improper handling is dangerous. The manufacturer is not responsible for material damage caused by improper handling (when putting the equipment into operation or during operation). The organization that put the boiling pan into operation must well know the operator with the instructions for use and instruct him!!!

When the boiling pan is in operation, we recommend opening the top cover carefully to prevent possible injuries and scalding from hot steam.

Before using the boiling pan for the first time, clean it (lukewarm water + neutral detergent) and wipe it dry. It is forbidden to use the equipment without supervision! **If a defect or malfunction is detected, the equipment must be immediately taken out of operation, disconnected from the power supply and a service technician must be called.**

Warning!

After turning on the boiling pan, it is necessary to monitor the pressure on the safety valve. If the pressure gauge needle rises, this pressure must be released manually by pressing the small protrusion on the left part of the safety valve. This action will release cold air from the duplicator. Repeat this process about 3 times.

Turning off the equipment - putting the boiling pan to rest

This state must be observed whenever the boiling pan is not expected to be in operation, or whenever the operator leaves the kitchen for a long time:

- turn the power control switch to the "0" position
- turn off the main switch
- turn off the main switch for the electrical power supply to the boiling pan and close the water supply.

9. Maintenance and cleaning of the equipment

WARNING!

Before cleaning and maintenance, it is necessary to turn off the boiling pan from the electrical network. The equipment must not be cleaned with water spray!!!

Any intervention in the equipment structure IS FORBIDDEN!!!

After the end of daily operation, the boiling pan must be thoroughly washed with lukewarm water with neutral detergent and wiped dry. It is necessary to ensure that the parts being cleaned (inside the duplicator) are cooled down. Do not use washing powders or cleaning detergents that can damage these parts on stainless steel parts. Avoid detergents containing a high concentration of chlorine, which can cause corrosion of stainless steel material (top plate, cooking tank and lid). Therefore, before using such a product, you should carefully read its composition and instructions for use. We recommend washing the duplicator with ordinary detergents. Sandpaper and wire brushes must not be used for cleaning. For larger dirt, a synthetic sponge should be used. **Stainless steel can also rust due to the ingress of metal impurities through the water supply, chlorine levels in the service water exceeding 2 mg/l, due to a higher salt concentration, pH outside the range of 7.2-7.6, or due to contact with other materials (e.g. copper) or due to the incorrect choice of detergent**

IN CASE OF FAILURE TO COMPLY WITH THE ABOVE CONDITIONS, THE CUSTOMER WILL LOSE THE RIGHT TO WARRANTY SERVICE.

Regular inspection by a service organization is recommended!

After the first three months of operation and then during regular annual inspections, it is necessary to check the tightness of the water distribution, the fastening of the wires. Approximately every month, it is necessary to check the operation of the safety valve. The reliable locking of the lid in the upper position can be adjusted by tightening the cover nuts on the lid hinge.

The service life of the heating elements (mounted in a double jacket) will also be greatly affected by the quality of the water in which they are placed. They must be regularly cleaned by descaling so that the layer of limescale does not exceed 1 mm in thickness.

Depending on the hardness of the water in the given place of operation, it is necessary to check and possibly clean the water level sensor probes of the duplicator from limescale at least twice a year.

For the treatment of GASTRO-HAAL equipment, the manufacturer recommends using TIEFFE brand cleaning agents, which are specially tested, proven and suitable by the manufacturer.

10. Important instructions

1. During shipment, the boiling pan is mounted on a transport pallet and transported by a forklift. When carrying it, it is possible to grab the boiling pan by the lower frame. It is also allowed to insert the transport trolley between the legs.
2. Installation of the boiling pan and initial commissioning may only be carried out by an authorized organization or worker who has signed a service contract for warranty and post-warranty work with the manufacturer.
3. Connection to the electrical distribution may only be carried out by a worker who is authorized to do this activity.

4. The electrical distribution must comply with technical standards.
5. The electric boiling pan may only be operated by an adult over 18 years of age, trained, and demonstrably familiar with the boiling pan operation and maintenance instructions. The operator must comply with applicable hygiene and safety regulations throughout the entire work period.
6. The water connection to the tap can only be used with hygienically safe "hoses for liquid food".
7. The operator must be instructed in accordance with the regulation.
8. If the described elements (labels) on the equipment are lost, destroyed, or illegible, the marking must be restored to its original condition.

We declare that the product complies with the safety regulations when the instructions given in this manual are followed and when used accordingly.

The main switch is not a standard accessory and is not supplied with the electric boiling pan. The main switch must be located within reach of the operator. Each boiling pan must have a separate main switch.

11. Boiling pan location

From the point of view of fire safety requirements, it is necessary to respect EN when placing, installing and using the equipment,

- the boiling pan must be placed on a solid, hard and non-combustible floor, preferably concrete, ceramic tiles, etc.,
- the space under the boiling pan must be kept clean, no flammable or other objects may be placed here.
- the location of the boiling pan at the workplace should be decided by the designer and the project approved.

WARNING!

For safety reasons, the boiling pan can only be stored up to the lowest temperature of +1°C.

12. Attachments

The completeness of the delivery consists of the equipment itself, User manual, Declaration of conformity, Warranty certificate, Reclamation protocol and Risk analysis.

WARNING

When making a complaint, inform the installation company about the name, type, serial number, year of production and date of installation.

12.1. Safety valve

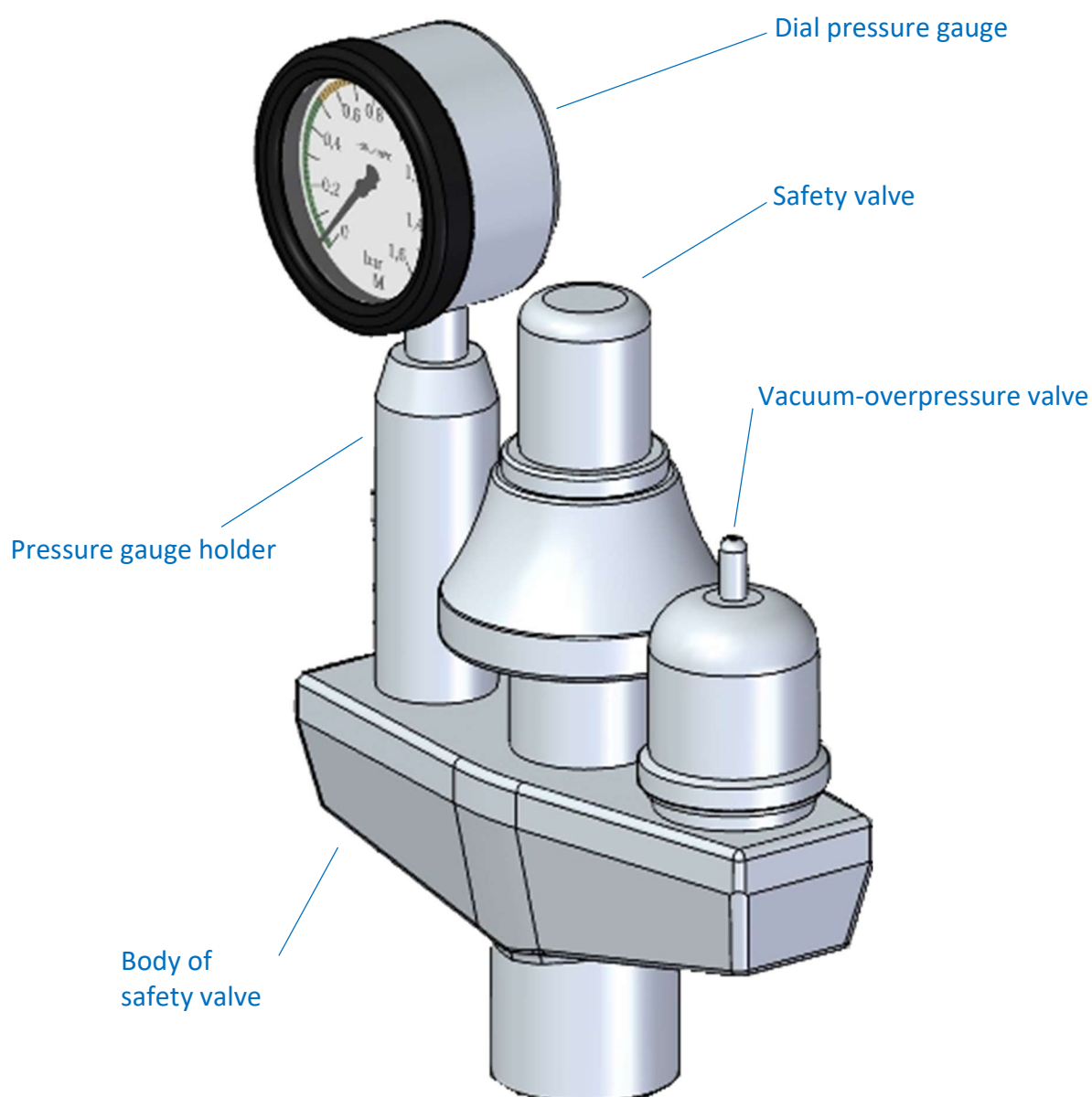

12.2. Connection dimensions

P.KE-785-O

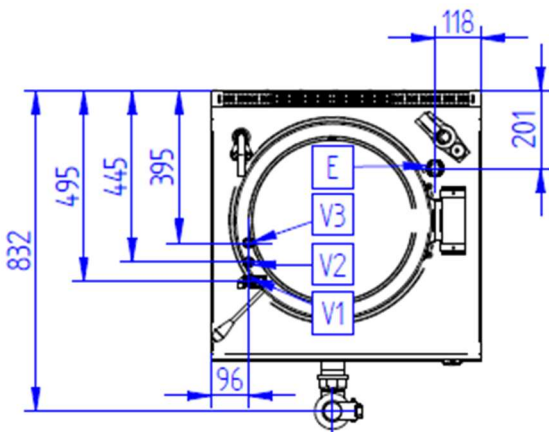
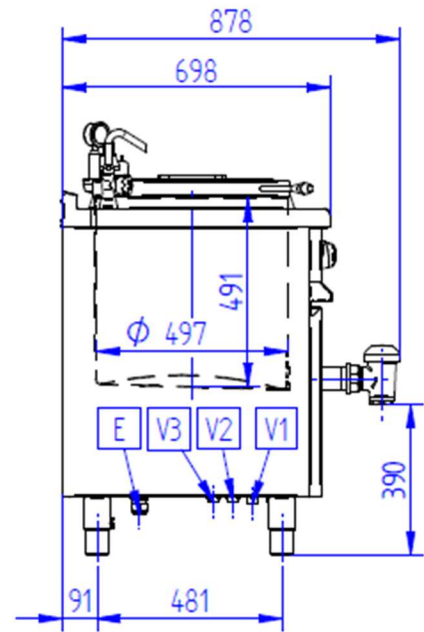
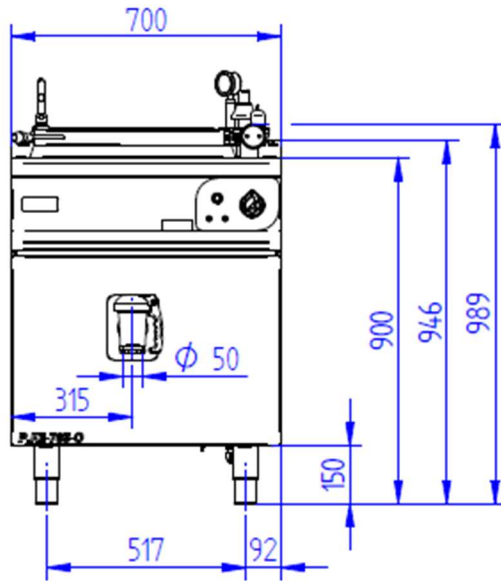

P.KE-785-O	
V1	Cold water G3/4 (duplicator)
V2	Cold water G3/4 (cooking tank)
V3	Hot water G3/4 (on request)
E	Electric connection

P.KE-85-O

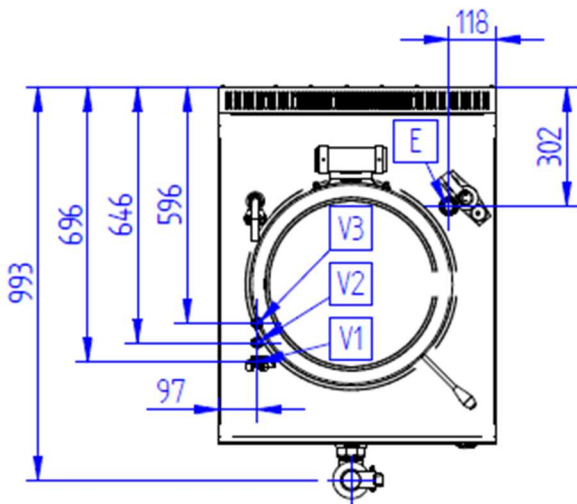
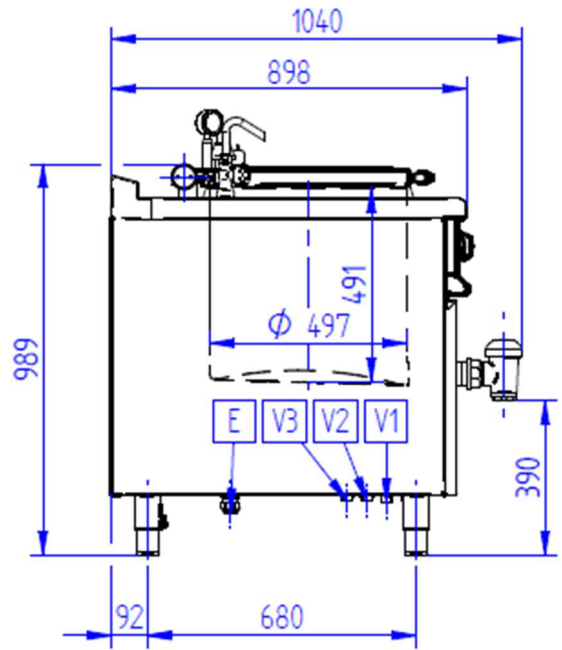
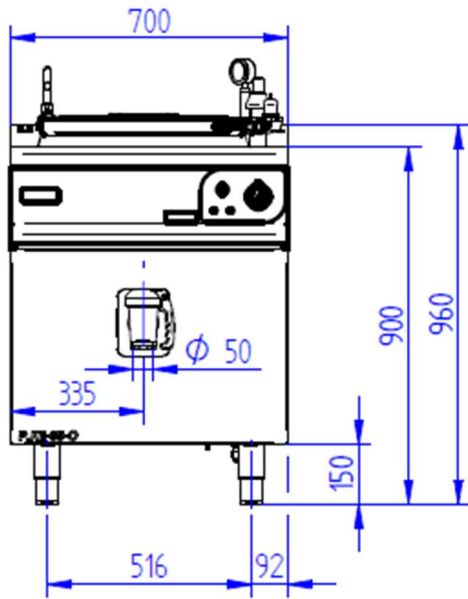

P.KE-85-O	
V1	Cold water G3/4 (duplicator)
V2	Cold water G3/4 (cooking tank)
V3	Hot water G3/4 (on request)
E	Electric connection

P.KE-100

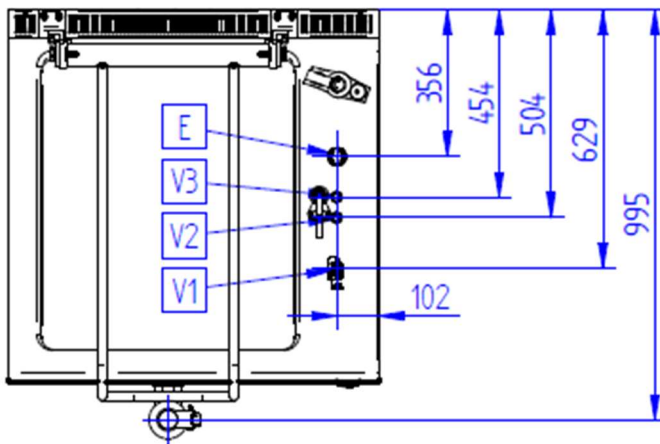
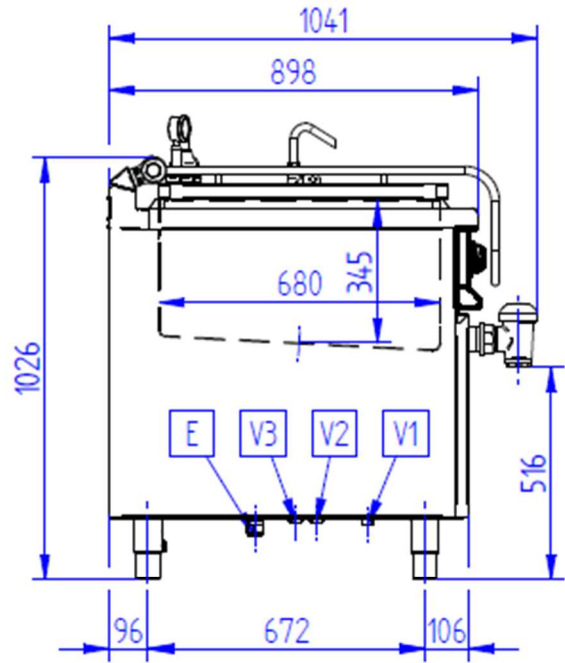
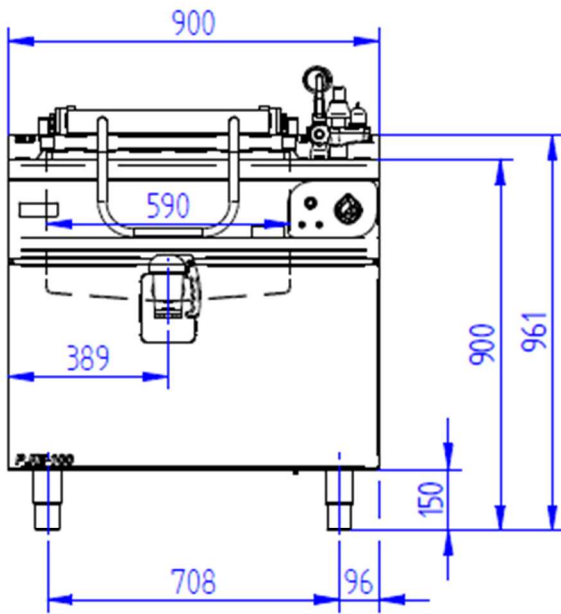

P.KE-100	
V1	Cold water G3/4 (duplicator)
V2	Cold water G3/4 (cooking tank)
V3	Hot water G3/4 (on request)
E	Electric connection

P.KE-100-O

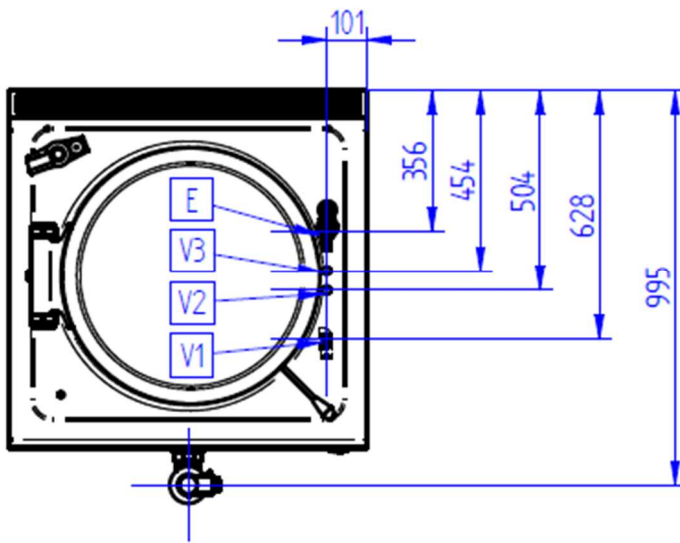
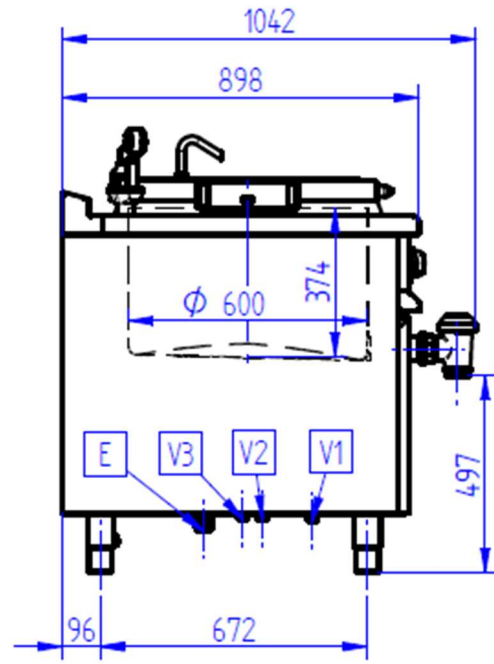
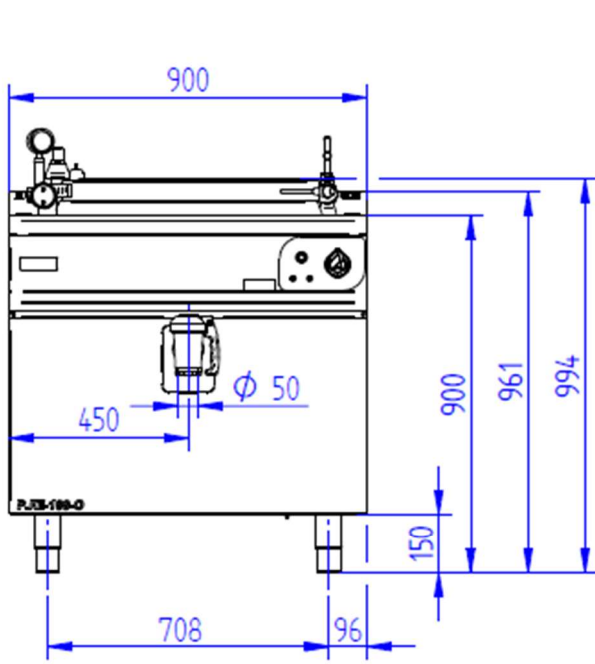

P.KE-100-O	
V1	Cold water G3/4 (duplicator)
V2	Cold water G3/4 (cooking tank)
V3	Hot water G3/4 (on request)
E	Electric connection

P.KE-150

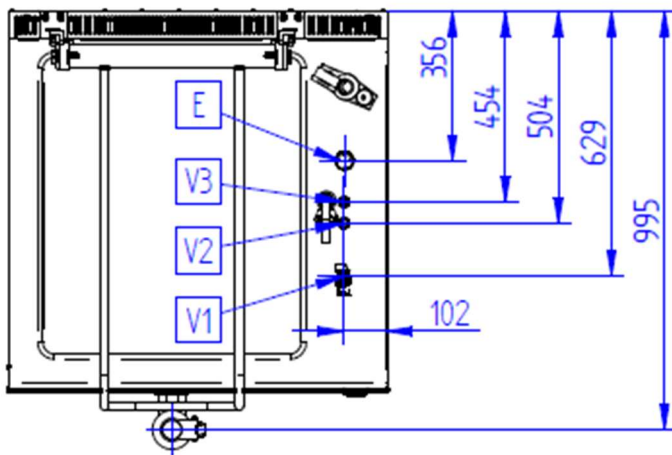
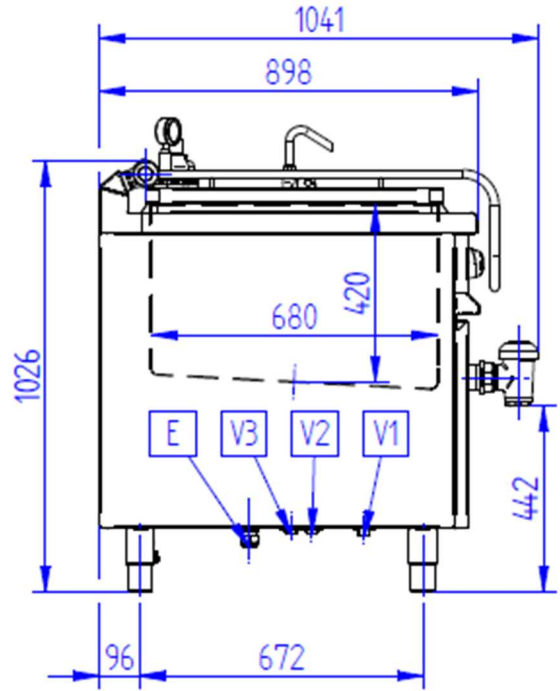
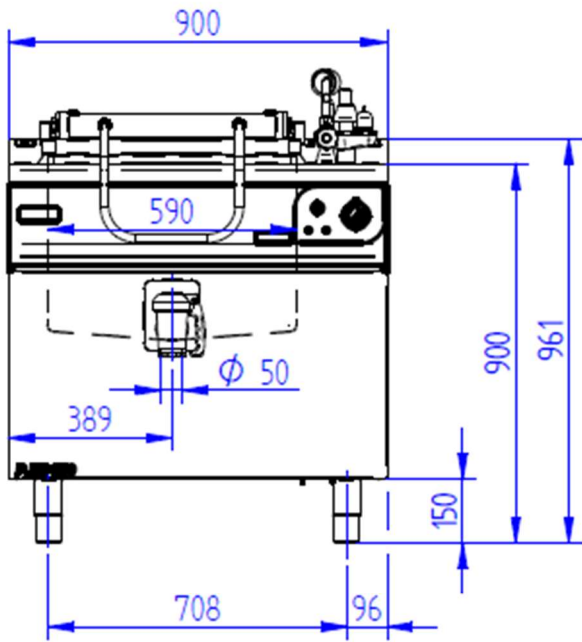

P.KE-150	
V1	Cold water G3/4 (duplicator)
V2	Cold water G3/4 (cooking tank)
V3	Hot water G3/4 (on request)
E	Electric connection

P.KE-150-O

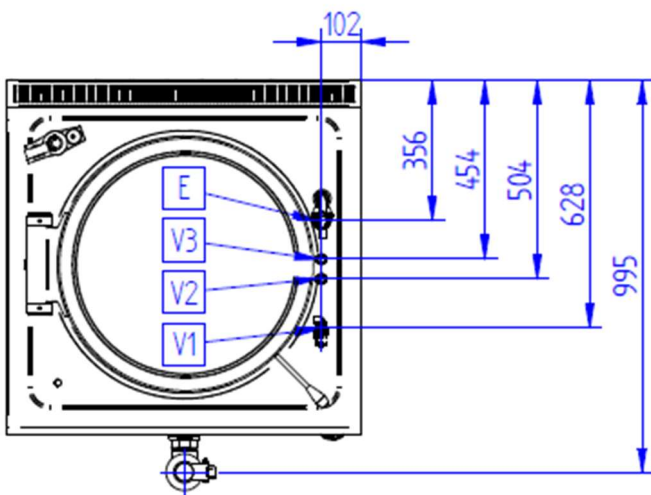
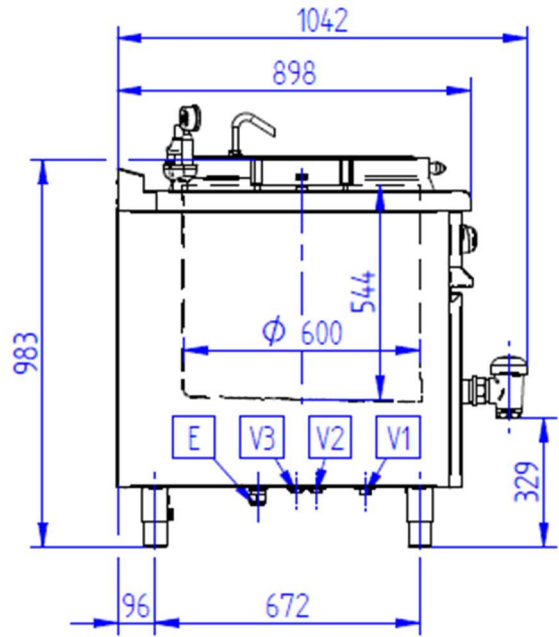
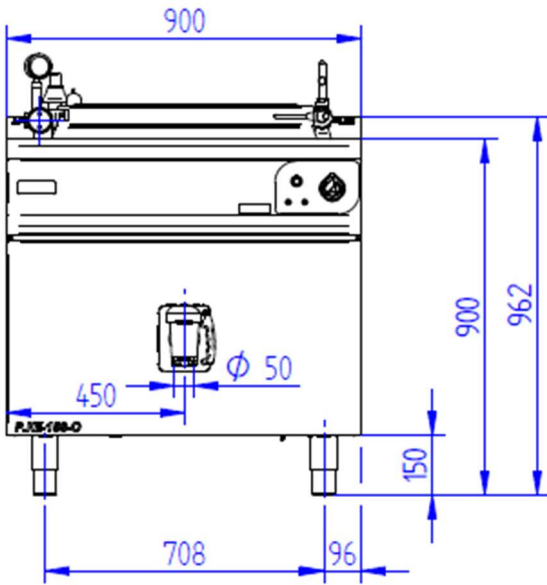

P.KE-150-O	
V1	Cold water G3/4 (duplicator)
V2	Cold water G3/4 (cooking tank)
V3	Hot water G3/4 (on request)
E	Electric connection

P.KE-200

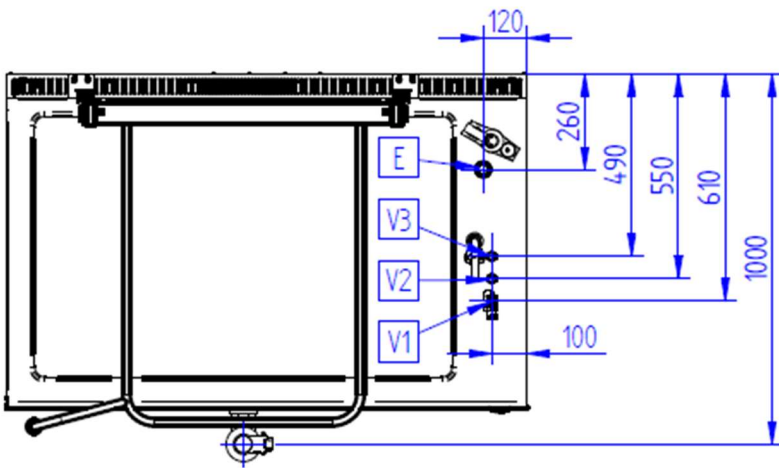
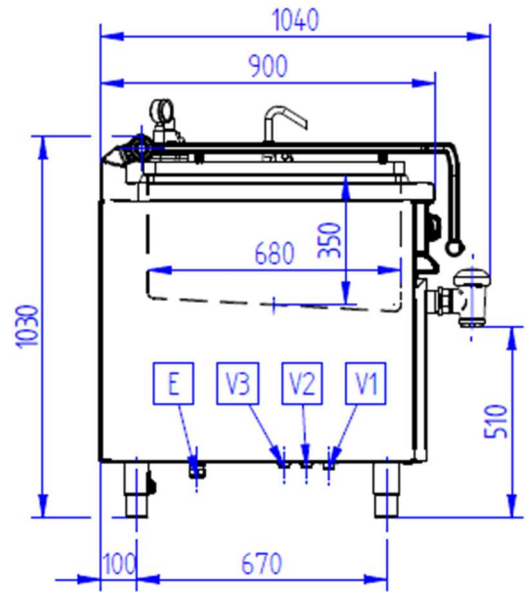
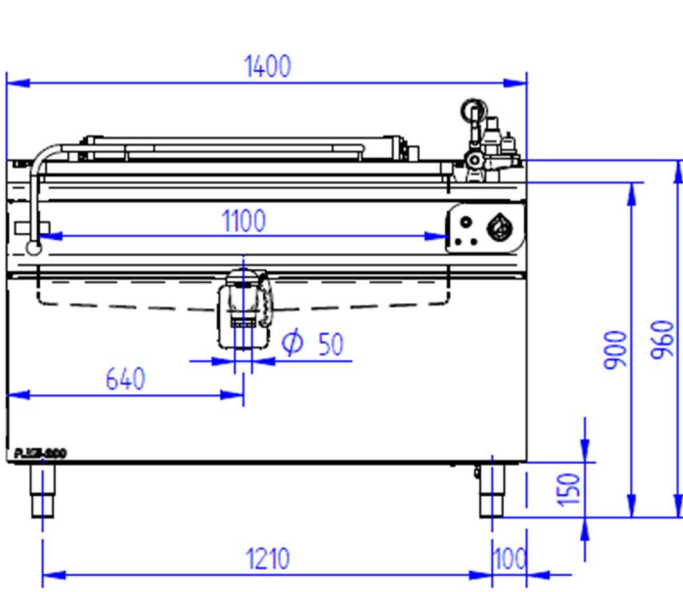

P.KE-200	
V1	Cold water G3/4 (duplicator)
V2	Cold water G3/4 (cooking tank)
V3	Hot water G3/4 (on request)
E	Electric connection

P.KE-300

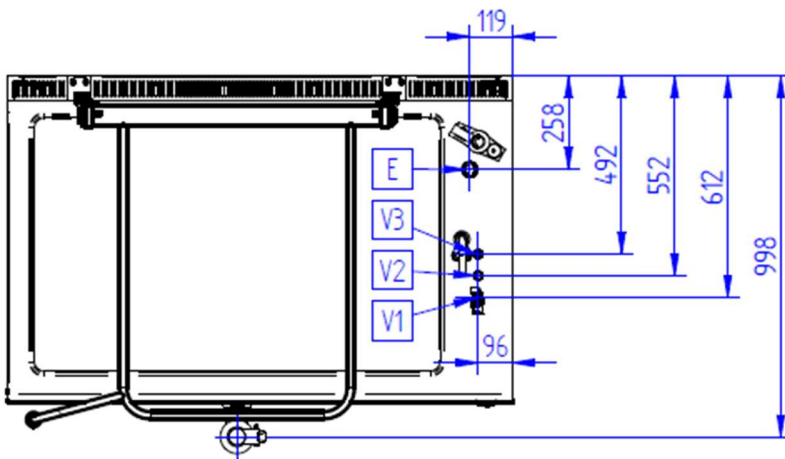
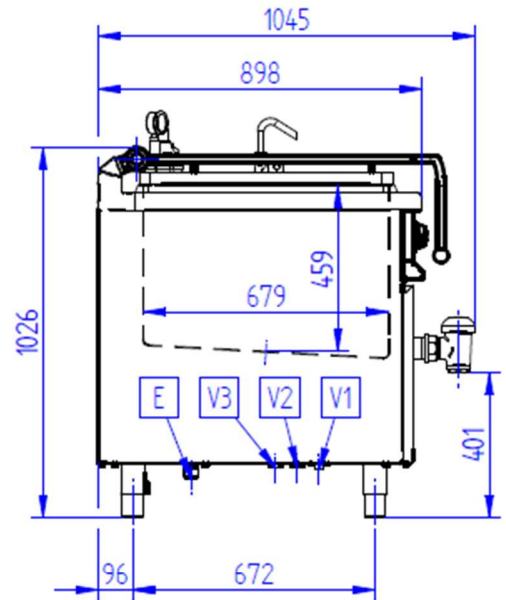
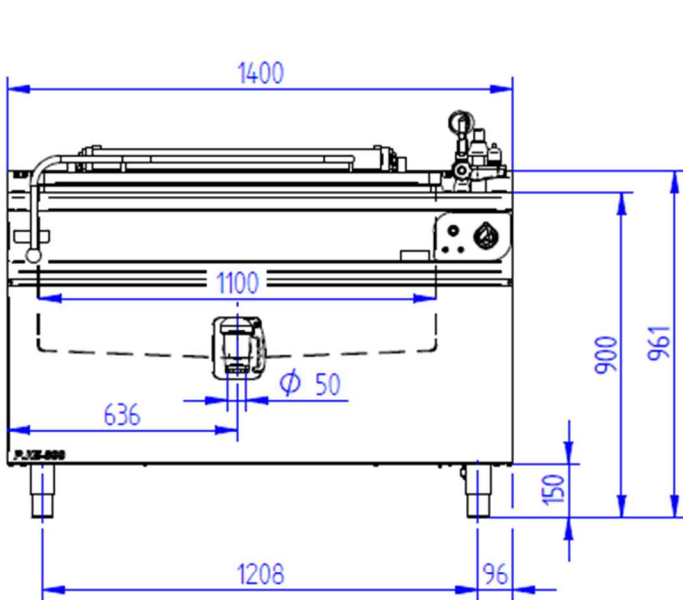

P.KE-300	
V1	Cold water G3/4 (duplicator)
V2	Cold water G3/4 (cooking tank)
V3	Hot water G3/4 (on request)
E	Electric connection

P.KE-400

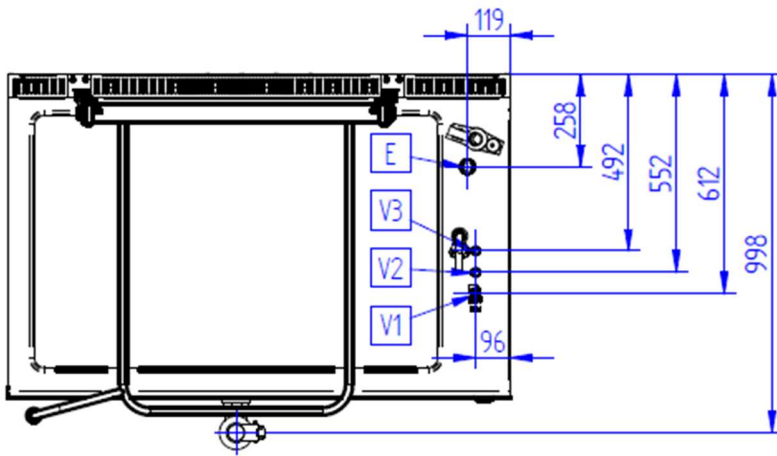
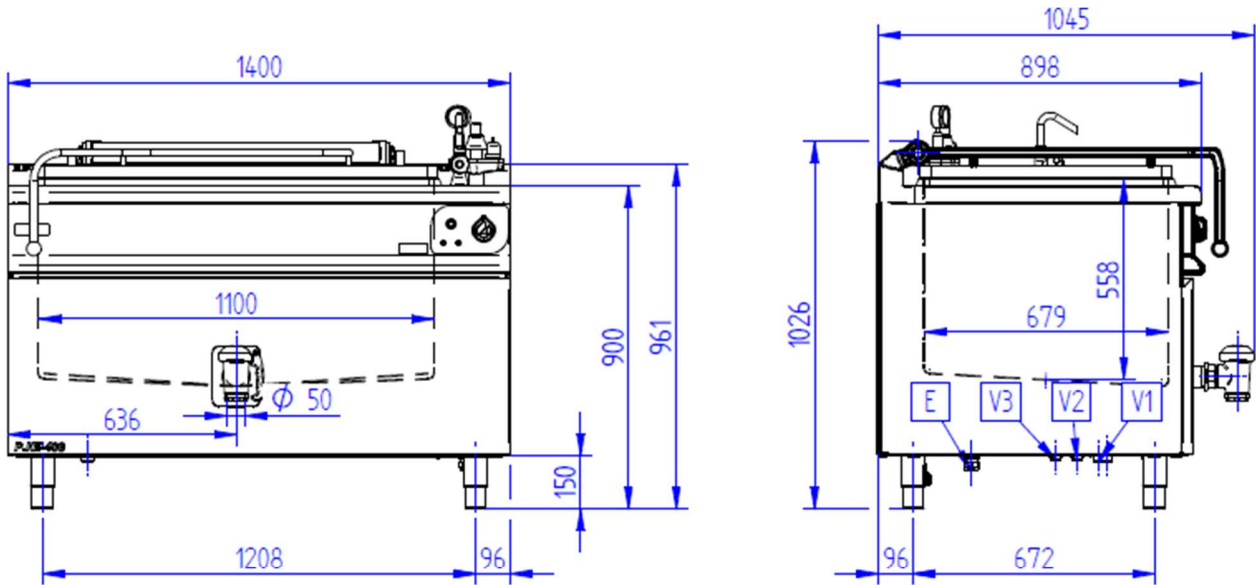

P.KE-400	
V1	Cold water G3/4 (duplicator)
V2	Cold water G3/4 (cooking tank)
V3	Hot water G3/4 (on request)
E	Electric connection

P.KE-500

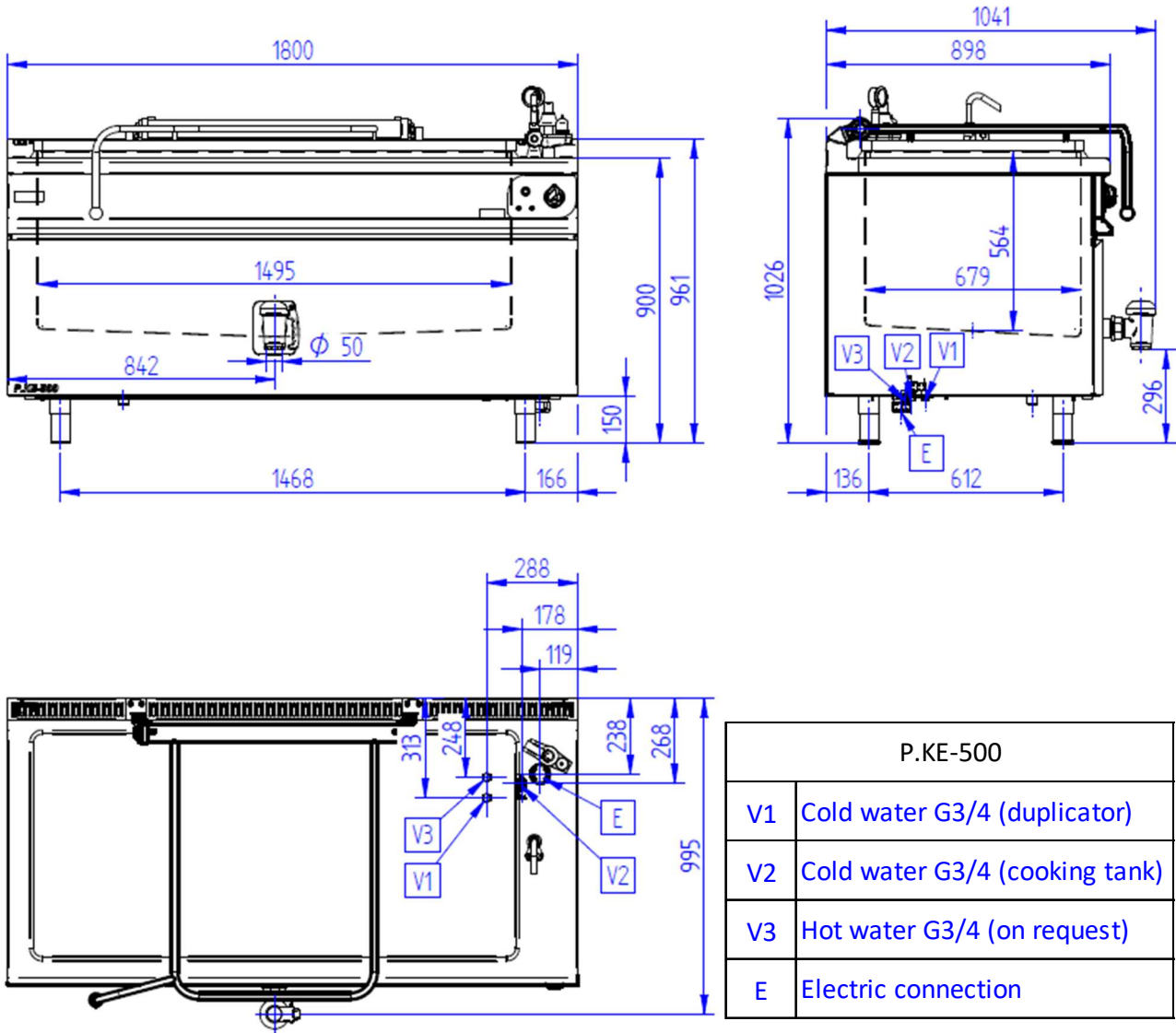

12.3. Electric wiring diagram

P.KE-785-O, P.KE-85-O, P.KE-100-O, P.KE-100

LEGEND:

- HS – main terminal board 400 V
- SM – electronic of water filling
- HV – main switch
- EV – electromagnetic valve of water filling
- S1 – water level sensor maximum
- S2 – water level level sensor minimum
- ST1, ST2, ST3 – contactor
- BT – safety thermostat
- TS – pressure switch
- OT1 – OT2 – heating elements
- K1 – light of water in duplicator
- K2 – light of heating
- P – power switch

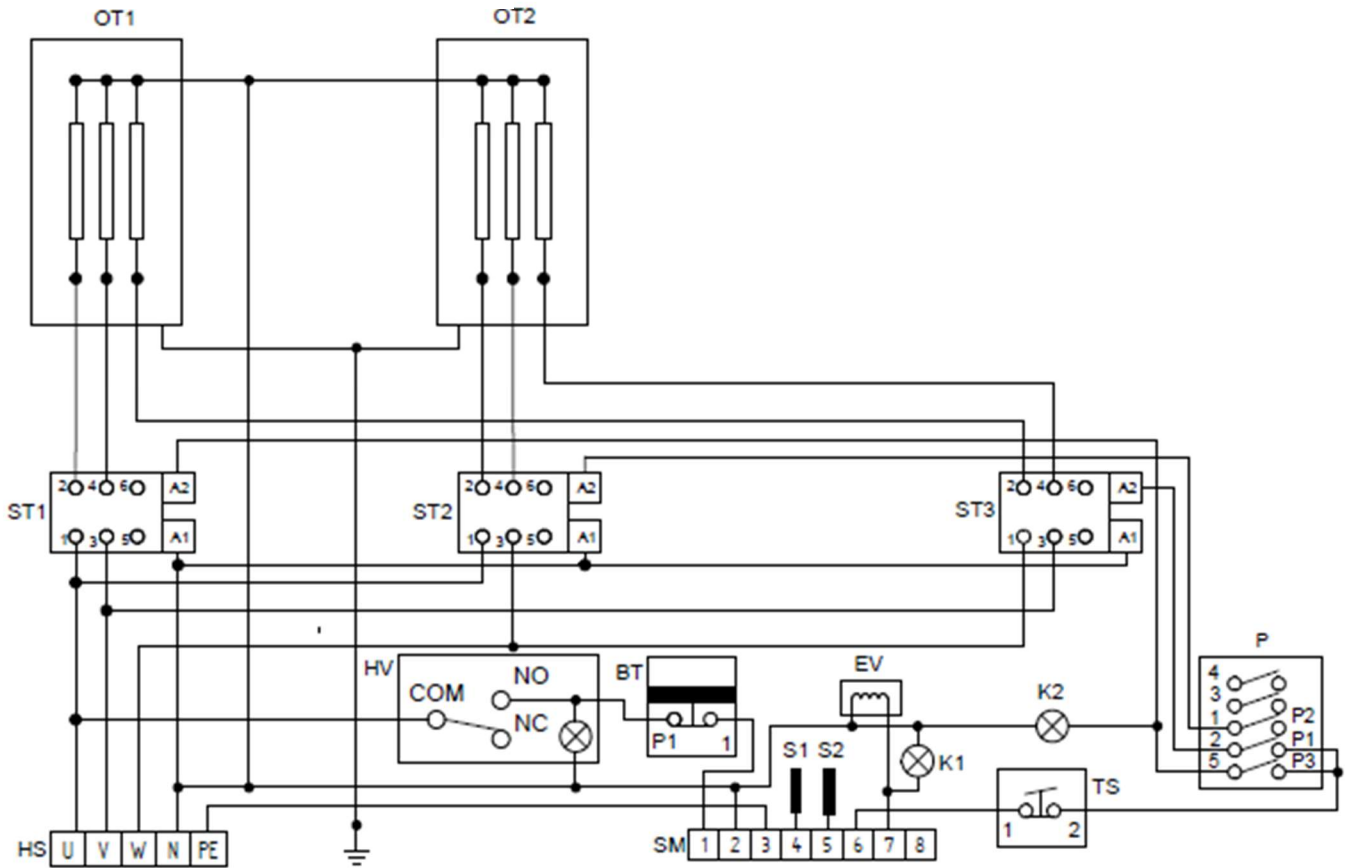

P.KE-150-O, P.KE-150

LEGEND:

- HS – main terminal board 400 V
- SM – electronic of water filling
- HV – main switch
- EV – electromagnetic valve of water filling
- S1 – water level sensor maximum
- S2 – water level level sensor minimum
- ST1, ST2, ST3 – contactor
- BT – safety thermostat
- TS – pressure switch
- OT1 – OT3 – heating elements
- K1 – light of water in duplicator
- K2 – light of heating
- P – power switch

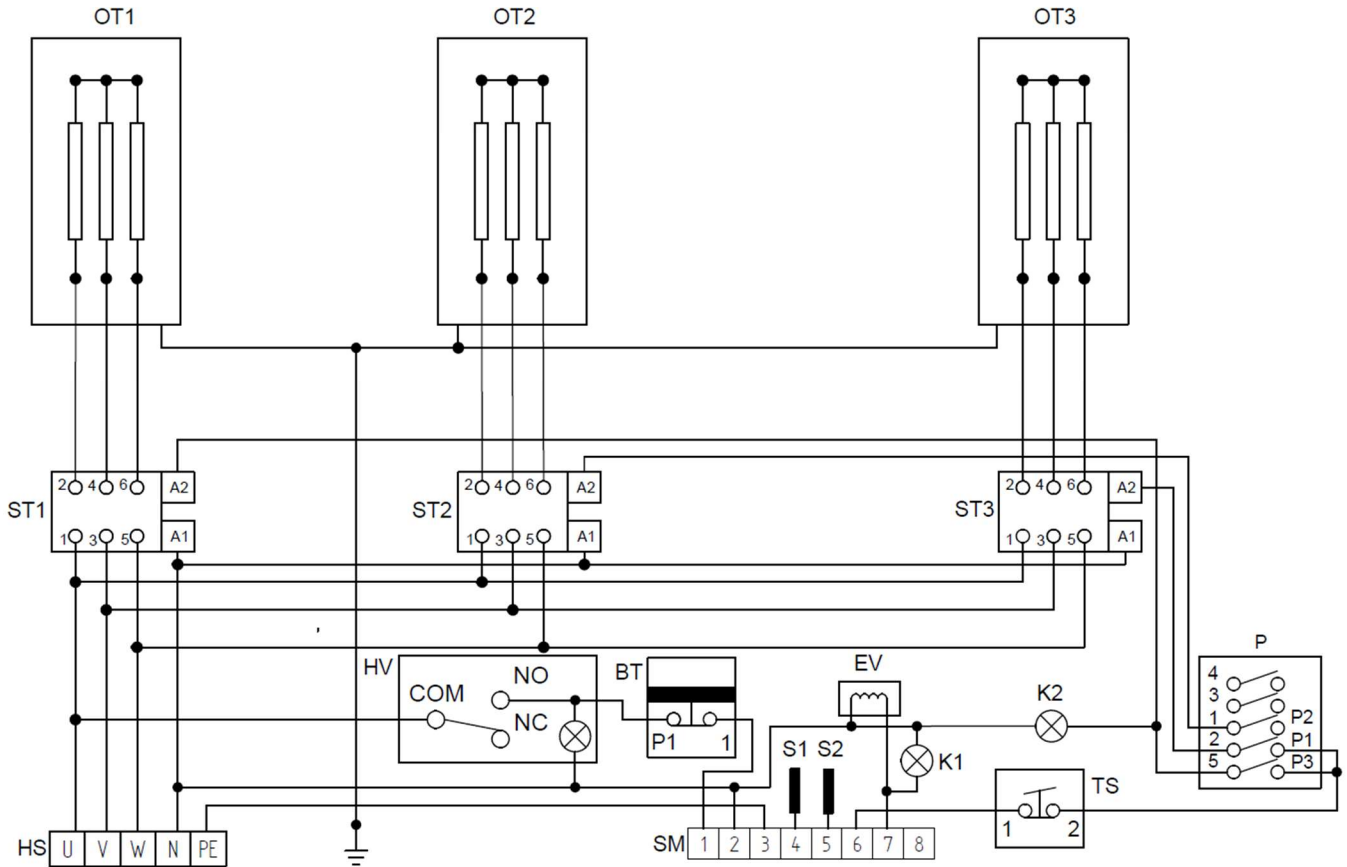

P.KE-200

LEGEND:

- HS – main terminal board 400 V
- SM – electronic of water filling
- HV – main switch
- EV – electromagnetic valve of water filling
- S1 – water level sensor maximum
- S2 – water level sensor minimum
- ST1, ST2, ST3 – contactor
- BT – safety thermostat
- TS – pressure switch
- OT1 – OT4 – heating elements
- K1 – light of water in duplicator
- K2 – light of heating
- P – power switch

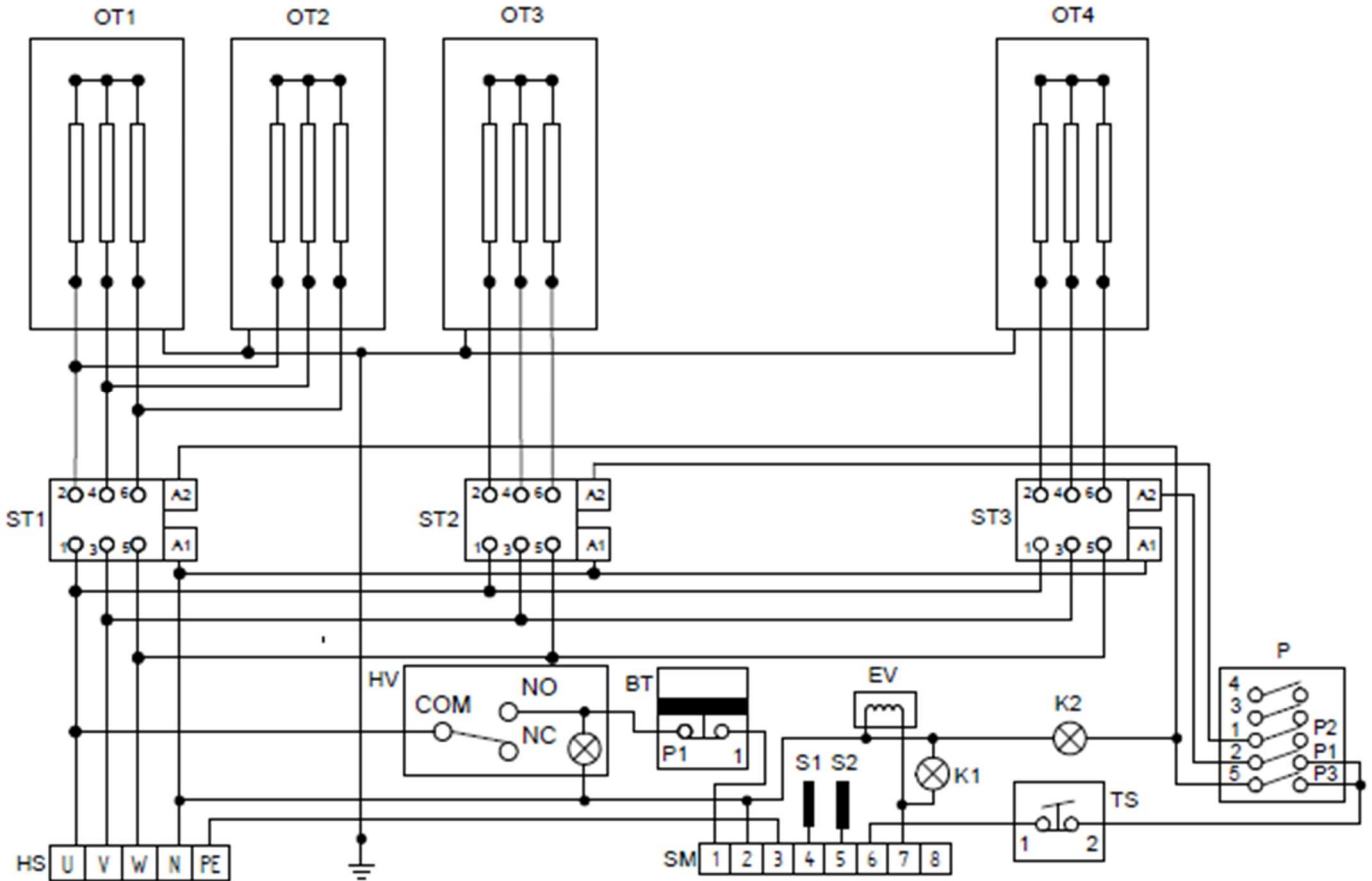

P.KE-300

LEGEND:

- HS – main terminal board 400 V
- SM – electronic of water filling
- HV – main switch
- EV – electromagnetic valve of water filling
- S1 – water level sensor maximum
- S2 – water level sensor minimum
- ST1, ST2, ST3 – contactor
- BT – safety thermostat
- TS – pressure switch
- OT1 – OT5 – heating elements
- K 1– light of water in duplicator
- K 2 – light of heating
- P – power switch

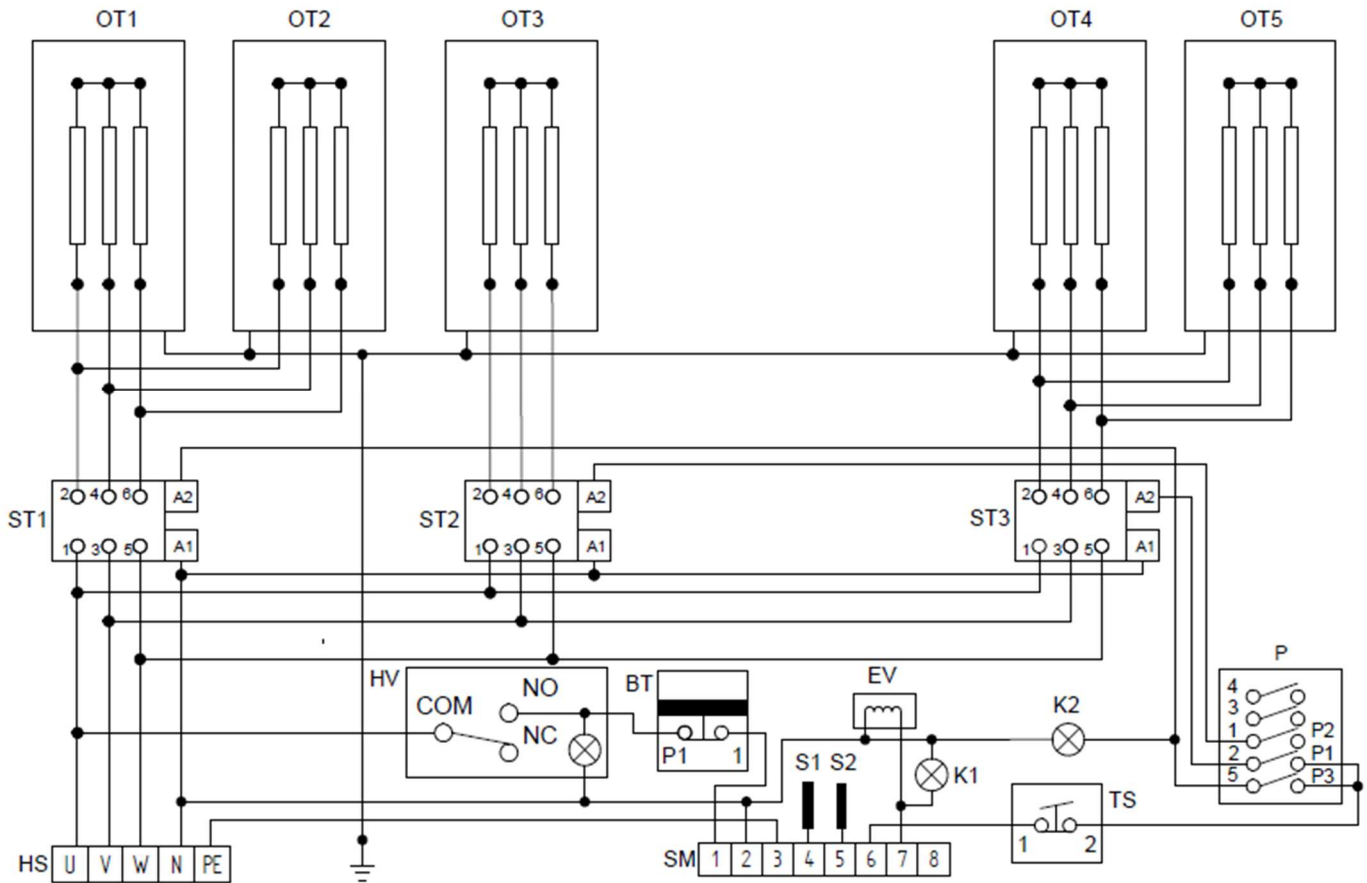

P.KE-400

LEGEND:

- HS – main terminal board 400 V
- SM – electronic of water filling
- HV – main switch
- EV – electromagnetic valve of water filling
- S1 – water level sensor maximum
- S2 – water level sensor minimum
- ST1, ST2, ST3 – contactor
- BT – safety thermostat
- TS – pressure switch
- OT1 – OT6 – heating elements
- K 1– light of water in duplicator
- K 2 – light of heating
- P – power switch

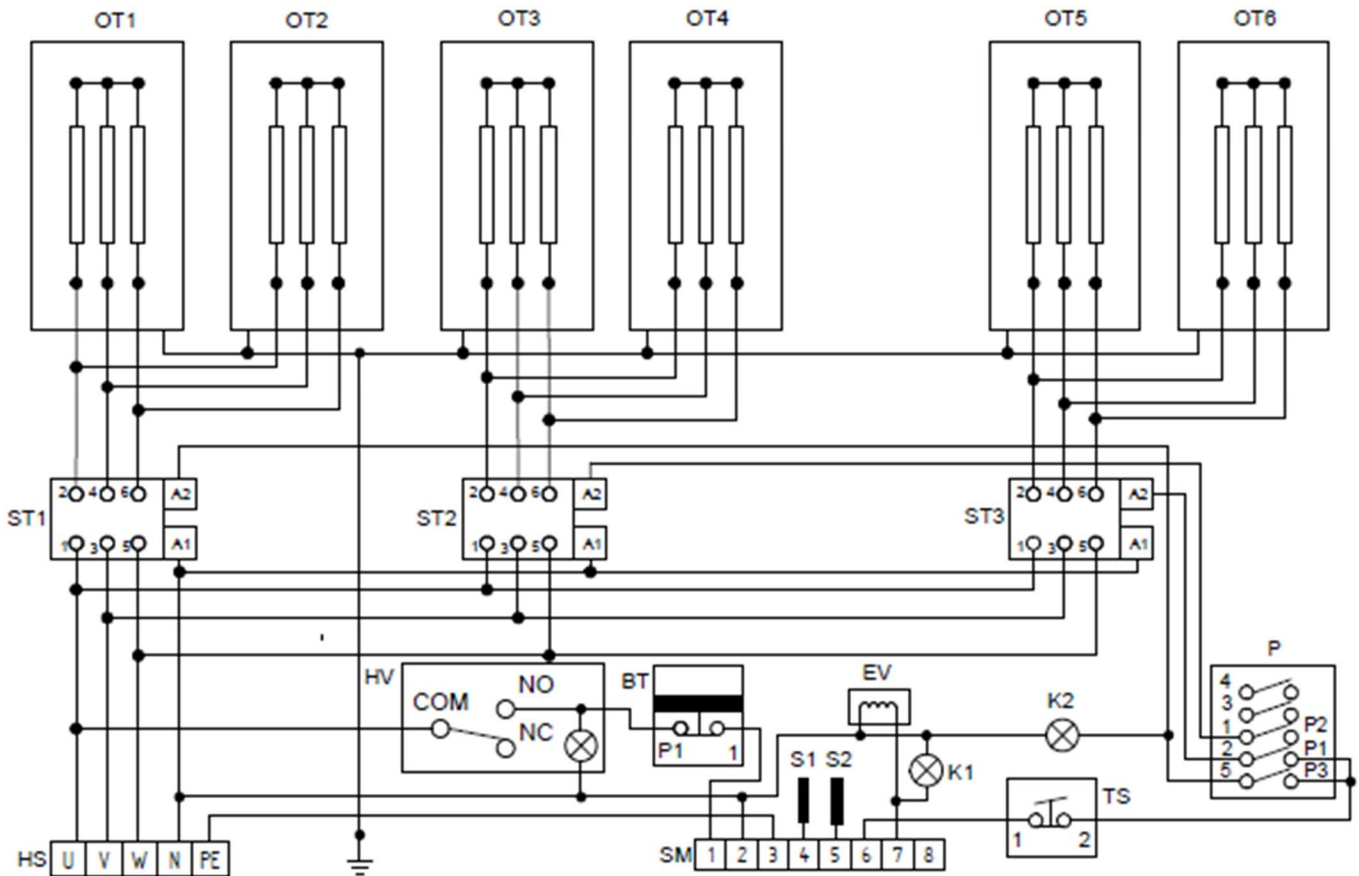

P.KE-500

LEGEND:

- HS – main terminal board 400 V
- SM – electronic of water filling
- HV – main switch
- EV – electromagnetic valve of water filling
- S1 – water level sensor maximum
- S2 – water level sensor minimum
- ST1, ST2, ST3 – contactor
- BT – safety thermostat
- TS – pressure switch
- OT1 – OT7 – heating elements
- K 1– light of water in duplicator
- K 2 – light of heating
- P – power switch

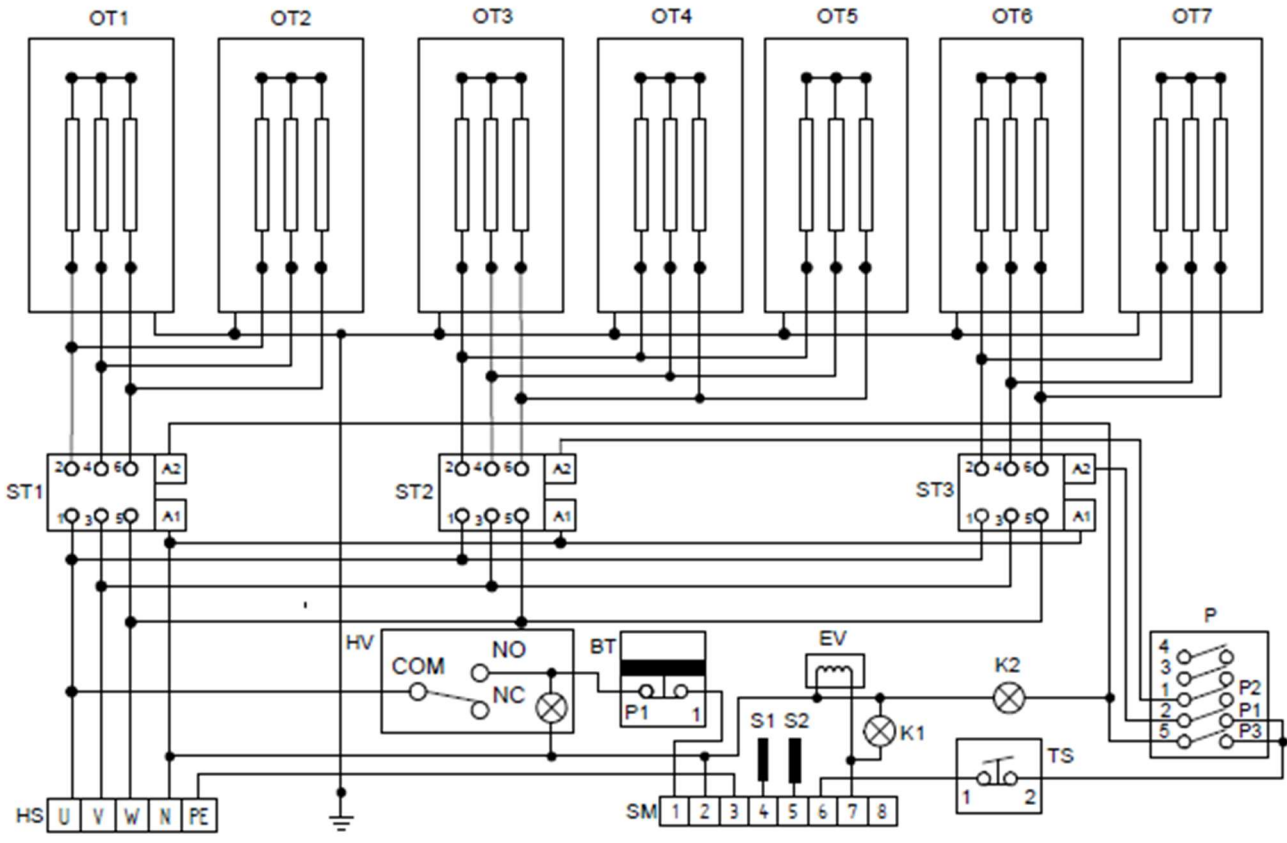

13. Instructions for use of the outlet valve

Purpose and installation

The outlet valve is used for discharging the liquid food or liquid intended for producing of food.

Maintenance

It's highly recommended the cleaning and maintenance after each use. Do not use the toxic or harmful detergents.

For proper functionality please follow these instructions:

1. Open and close the valve to confirm, that no more liquid is discharging from outlet valve.
2. Release the lower Allen screw (6), dismantle the metal ring (5) carefully, to not drop out the seal of metal ring (8) – upward take of the insert of outlet valve (2).
3. Clean all parts, it is necessary to grease the insert of outlet valve with food Vaseline.
4. Process of outlet valve assembling is the opposite to the dismantling.

Description:

- 1 – body of outlet valve
- 2 – insert of outlet valve
- 3 – handle of outlet valve
- 4 – winch of handle
- 5 – metal ring
- 6 – Allen screw
- 7 – seal ring of outlet valve
- 8 – seal of metal ring



SUPPLIER:

(add the contact details)

SERVICE TECHNICIAN:

(add the contact details)

MANUFACTURER

GASTRO – HAAL, s.r.o. Povazska 16, 940 67 Nove Zamky, SR +421 35 6 430 115 gastro@gastrohaal.sk
Company ID: 31435076 VAT ID: 2020413659 VAT ID: SK2020413659 www.gastrohaal.sk/en