

Model:	700.BGK-80	800x700x900 [mm]	
Power rating	16 kW		
	13757 kcal/h		
Working capacity	80 dm ³		
Drain valve	1 1/2"		
Rated voltage, type of current	230V ~		
Max. working pressure	0.5 bar		
Water connection	G 1/2		
Gas connection	R1/2		
Gas consumption	E G20 [20mbar]	m ³ /h	1.7
	Lw G27 [20mbar]	m ³ /h	2.05
	3B/P G30 [37mbar]	kg/h	0.48

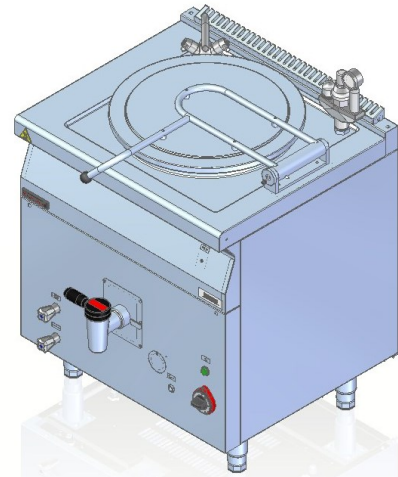

Description:

Gas boiling pans are made of high-grade stainless steels. Working plate made of AISI 304 stainless steel with thickness ≠ 1.5mm, tank bottom made of polished AISI 316L stainless steel. The device is equipped with pilot burner with flame safety device. Indirect heating system prevents burning of foods being prepared. Large drain valve allows for fast pouring of soups to other vessels. The device is fitted with safety valve.

700.BGK-80

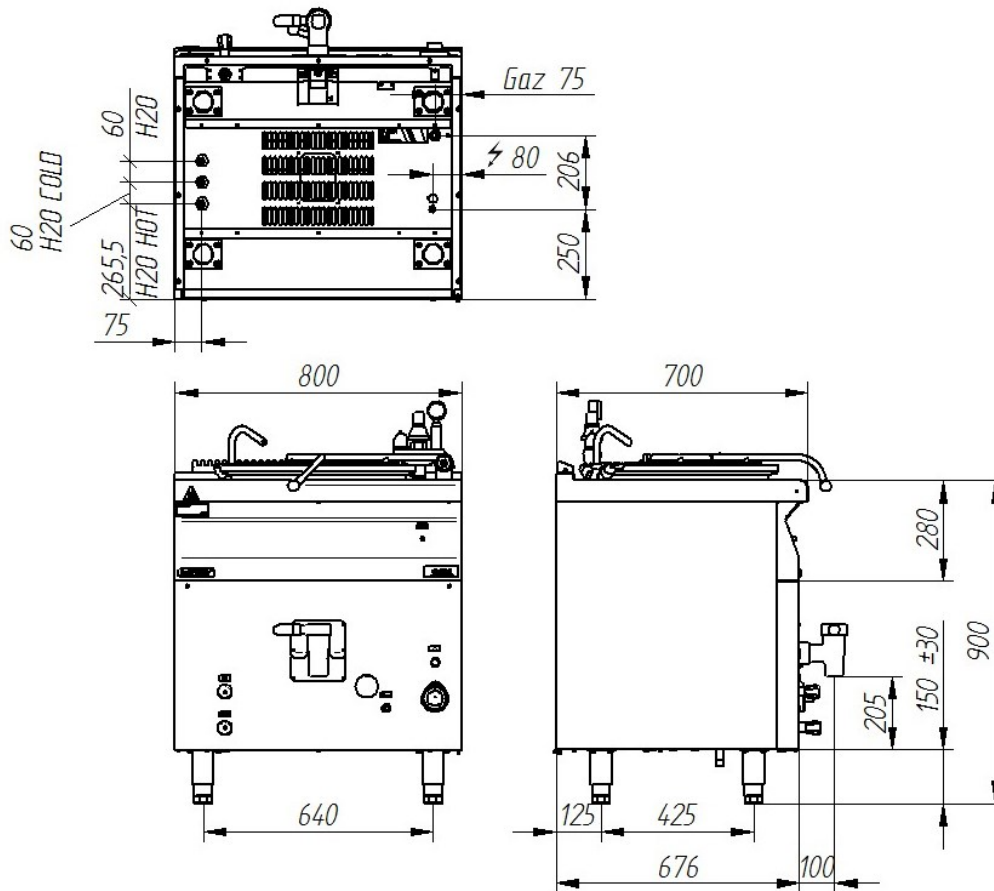

The picture is for reference only; final product may be slightly different from the presented example.